

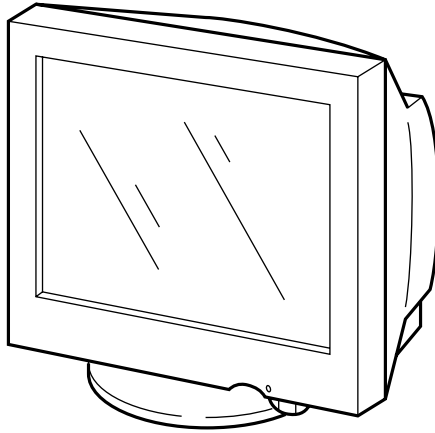

# CPD-E400/E400E/E400P

## SERVICE MANUAL



*CPD-E400*  
**US Model**  
**Canadian Model**  
Chassis No. SCC-L30K-A

*CPD-E400E*  
**AEP Model**  
Chassis No. SCC-L30K-A

*CPD-E400P*  
**AEP Model**  
Chassis No. SCC-L30S-A

### F99 CHASSIS

#### SPECIFICATIONS

CRT	0.24 mm aperture grille pitch (center) 19 inches measured diagonally 90-degree deflection FD Trinitron	AC input voltage/current Power consumption Operating temperature Dimensions	100 to 240 V, 50 – 60 Hz, Max. 2.0 A 140 W 10°C to 40°C Approx. 446 × 464 × 461 mm (w/h/d) (17 <sup>5</sup> / <sub>8</sub> × 18 <sup>3</sup> / <sub>8</sub> × 18 <sup>1</sup> / <sub>4</sub> inches)
Viewable image size	Approx. 365 × 274 mm (w/h) (14 <sup>3</sup> / <sub>8</sub> × 10 <sup>7</sup> / <sub>8</sub> inches) 18.0" viewing image	Mass Plug and Play	Approx. 26 kg (57 lb 5 oz) DDC1/DDC2B/DDC2Bi/GTF
Resolution			
Maximum	Horizontal: 1800 dots Vertical: 1440 lines		
Recommended	Horizontal: 1280 dots Vertical: 1024 lines		
Standard image area	Approx. 352 × 264 mm (w/h) (13 <sup>7</sup> / <sub>8</sub> × 10 <sup>1</sup> / <sub>2</sub> inches)		
Deflection frequency*	Horizontal: 30 to 96 kHz Vertical: 48 to 120 Hz		

- \* Recommended horizontal and vertical timing condition
- Horizontal sync width should be more than 1.0 μsec.
  - Horizontal blanking width should be more than 3.0 μsec.
  - Vertical blanking width should be more than 500 μsec.

Design and specifications are subject to change without notice.

## TRINITRON® COLOR COMPUTER DISPLAY

# SONY®

After correcting the original service problem, perform the following safety checks before releasing the set to the customer:

1. Check the area of your repair for unsoldered or poorly-soldered connections. Check the entire board surface for solder splashes and bridges.
2. Check the interboard wiring to ensure that no wires are "pinched" or contact high-wattage resistors.
3. Check that all control knobs, shields, covers, ground straps, and mounting hardware have been replaced. Be absolutely certain that you have replaced all the insulators.
4. Look for unauthorized replacement parts, particularly transistors, that were installed during a previous repair. Point them out to the customer and recommend their replacement.
5. Look for parts which, though functioning, show obvious signs of deterioration. Point them out to the customer and recommend their replacement.
6. Check the line cords for cracks and abrasion. Recommend the replacement of any such line cord to the customer.
7. Check the B+ and HV to see if they are specified values. Make sure your instruments are accurate; be suspicious of your HV meter if sets always have low HV.
8. Check the antenna terminals, metal trim, "metallized" knobs, screws, and all other exposed metal parts for AC Leakage. Check leakage as described below.

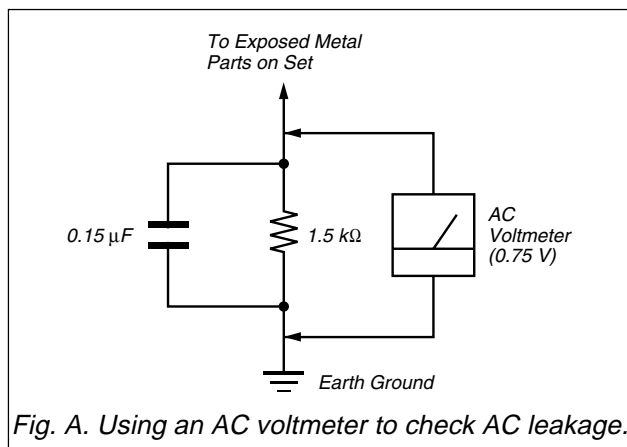

Fig. A. Using an AC voltmeter to check AC leakage.

## LEAKAGE TEST

The AC leakage from any exposed metal part to earth ground and from all exposed metal parts to any exposed metal part having a return to chassis, must not exceed 0.5 mA (500 microamperes).

Leakage current can be measured by any one of three methods.

1. A commercial leakage tester, such as the Simpson 229 or RCA WT-540A. Follow the manufacturers' instructions to use these instruments.
2. A battery-operated AC milliammeter. The Data Precision 245 digital multimeter is suitable for this job.
3. Measuring the voltage drop across a resistor by means of a VOM or battery-operated AC voltmeter. The "limit" indication is 0.75 V, so analog meters must have an accurate low-voltage scale. The Simpson 250 and Sanwa SH-63Trd are examples of a passive VOMs that are suitable. Nearly all battery operated digital multimeters that have a 2 V AC range are suitable. (See Fig. A)

### WARNING!!

**NEVER TURN ON THE POWER IN A CONDITION IN WHICH THE DEGAUSS COIL HAS BEEN REMOVED.**

### SAFETY-RELATED COMPONENT WARNING!!

**COMPONENTS IDENTIFIED BY SHADING AND MARK  $\triangle$  ON THE SCHEMATIC DIAGRAMS, EXPLODED VIEWS AND IN THE PARTS LIST ARE CRITICAL FOR SAFE OPERATION. REPLACE THESE COMPONENTS WITH SONY PARTS WHOSE PART NUMBERS APPEAR AS SHOWN IN THIS MANUAL OR IN SUPPLEMENTS PUBLISHED BY SONY. CIRCUIT ADJUSTMENTS THAT ARE CRITICAL FOR SAFE OPERATION ARE IDENTIFIED IN THIS MANUAL. FOLLOW THESE PROCEDURES WHENEVER CRITICAL COMPONENTS ARE REPLACED OR IMPROPER OPERATION IS SUSPECTED.**

### AVERTISSEMENT!!

**NE JAMAIS METTRE SOUS TENSION QUAND LA BOBINE DE DEMAGNETISATION EST ENLEVÉE.**

### ATTENTION AUX COMPOSANTS RELATIFS À LA SÉCURITÉ!!

**LES COMPOSANTS IDENTIFIÉS PAR UNE TRAME ET UNE MARQUE  $\triangle$  SONT CRITIQUES POUR LA SÉCURITÉ. NE LES REMPLACER QUE PAR UNE PIÈCE PORTANT LE NUMÉRO SPECIFIÉ. LES RÉGLAGES DE CIRCUIT DONT L'IMPORTANCE EST CRITIQUE POUR LA SÉCURITÉ DU FONCTIONNEMENT SONT IDENTIFIÉS DANS LE PRÉSENT MANUEL. SUIVRE CES PROCÉDURES LORS DE CHAQUE REMPLACEMENT DE COMPOSANTS CRITIQUES, OU LORSQU'UN MAUVAIS FONCTIONNEMENT EST SUSPECTÉ.**

## POWER SAVING FUNCTION

This monitor meets the power-saving guidelines set by VESA, ENERGY STAR, and NUTEK. If the monitor is connected to a computer or video graphics board that is DPMS (Display Power Management Signaling) compliant, the monitor will automatically reduce power consumption in three stages as shown below.

Power mode	Power consumption	⏻ (power) indicator
normal operation	≤ 140 W	green
1 standby	≤ 15 W	green and orange alternate
2 suspend (sleep)*	≤ 15 W	green and orange alternate
3 active off** (deep sleep)*	≤ 3 W	orange
power off	0 W	off

\* “Sleep” and “deep sleep” are power saving modes defined by the Environmental Protection Agency.

\*\* When your computer is in a power saving mode, MONITOR IS IN POWER SAVE MODE appears on the screen if you press any button on the monitor. After a few seconds, the monitor enters the power saving mode again.

## DIAGNOSIS

This monitor is equipped with a self-diagnosis function. If there is a problem with your monitor or computer, the screen will go blank and the ⏻ (power) indicator will either light up green or flash orange. If the ⏻ (power) indicator is lit in orange, the computer is in power saving mode. Try pressing any key on the keyboard.

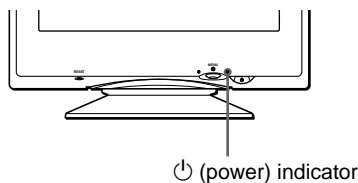

If all four color bars appear (white, red, green, blue), the monitor is working properly. Reconnect the video input cable and check the condition of your computer.

If the color bars do not appear, there is a potential monitor failure. Inform your authorized Sony dealer of the monitor's condition.

### If the ⏻ (power) indicator is flashing orange

**Press the ⏻ (power) button twice to turn the monitor off and then on.**

If the ⏻ (power) indicator lights up green, the monitor is working properly.

If the ⏻ (power) indicator is still flashing, there is a potential monitor failure. Count the number of seconds between orange flashes of the ⏻ (power) indicator and inform your authorized Sony dealer of the monitor's condition. Be sure to note the model name and serial number of your monitor. Also note the make and model of your computer and video board.

### If the ⏻ (power) indicator is green

- 1 Disconnect the video input cable or turn off the connected computer.**
- 2 Press the ⏻ (power) button twice to turn the monitor off and then on.**
- 3 Move the control button → for 2 seconds before the monitor enters power saving mode.**

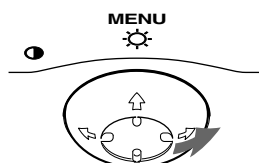

# CPD-E400/E400E/E400P

## TIMING SPECIFICATION

MODE AT PRODUCTION	MODE 1	MODE 2
RESOLUTION	738 X 414	1600 X 1200
CLOCK	28.322 MHz	202.500 MHz
HORIZONTAL		
H-FREQ	31.469 kHz usec	93.750 kHz usec
H. TOTAL	31.777	10.667
H. BLK	5.720	2.765
H. FP	0.318	0.316
H. SYNC	3.813	0.948
H. BP	1.589	1.501
H. ACTIV	26.057	7.901
- VERTICAL -		
V. FREQ(HZ)	70.087 Hz lines	75.000 Hz lines
V. TOTAL	449	1250
V. BLK	35	50
V. FP	5	1
V. SYNC	2	3
V. BP	28	46
V. ACTIV	414	1200
- SYNC -		
INT(G)	NO	NO
EXT(H/V)/POLARITY	YES N/P	YES P/P
EXT(CS) /POLARITY	NO	NO
INT/NON INT	NON INT	NON INT

99.10.26 VER.

## TABLE OF CONTENTS

<i>Section</i>	<i>Title</i>	<i>Page</i>
<b>1. GENERAL</b>	.....	1-1
<b>2. DISASSEMBLY</b>		
2-1.	Cabinet Removal .....	2-1
2-2.	Shield (EMI, Video), Side Cover (L and R) Removal .....	2-1
2-3.	A Board Removal .....	2-2
2-4.	Rear Shield Complete Assy, D Board Removal .....	2-2
2-5.	Service Position .....	2-3
2-6.	H Board Removal .....	2-3
2-7.	Picture Tube Removal .....	2-4
2-8.	Harness Location .....	2-5
<b>3. SAFETY RELATED ADJUSTMENT</b>	.....	3-1
<b>4. ADJUSTMENTS</b>	.....	4-1
<b>5. DIAGRAMS</b>		
5-1.	Block Diagrams .....	5-1
5-2.	Frame Schematic Diagram .....	5-5
5-3.	Circuit Boards Location .....	5-6
5-4.	Schematic Diagrams and Printed Wiring Boards .....	5-7
(1)	Schematic Diagram of A Board .....	5-9
(2)	Schematic Diagrams of D (a, b, c) Board ....	5-11
(3)	Schematic Diagrams of N, H Boards .....	5-19
5-5.	Semiconductors .....	5-21
<b>6. EXPLODED VIEWS</b>		
6-1.	Chassis .....	6-1
6-2.	Picture Tube .....	6-2
6-3.	Packing Materials .....	6-3
<b>7. ELECTRICAL PARTS LIST</b>	.....	7-1

The operating instructions mentioned here are partial abstracts from the Operating Instruction Manual. The page numbers of the Operating Instruction Manual remain as in the manual.

## SECTION 1 GENERAL

### Precautions

#### Warning on power connections

- Use the supplied power cord. If you use a different power cord, be sure that it is compatible with your local power supply.

#### For the customers in the U.S.A.

If you do not use the appropriate cord, this monitor will not conform to mandatory FCC standards.

Example of plug types



for 100 to 120 V AC



for 200 to 240 V AC

- Before disconnecting the power cord, wait at least 30 seconds after turning off the power to allow the static electricity on the screen's surface to discharge.
- After the power is turned on, the screen is demagnetized (degaussed) for about 5 seconds. This generates a strong magnetic field around the screen which may affect data stored on magnetic tapes and disks placed near the monitor. Be sure to keep magnetic recording equipment, tapes, and disks away from the monitor.

The equipment should be installed near an easily accessible outlet.

#### Installation

Do not install the monitor in the following places:

- on surfaces (rugs, blankets, etc.) or near materials (curtains, draperies, etc.) that may block the ventilation holes
- near heat sources such as radiators or air ducts, or in a place subject to direct sunlight
- in a place subject to severe temperature changes
- in a place subject to mechanical vibration or shock
- on an unstable surface
- near equipment which generates magnetism, such as a transformer or high voltage power lines
- near or on an electrically charged metal surface

#### Maintenance

- Clean the screen with a soft cloth. If you use a glass cleaning liquid, do not use any type of cleaner containing an anti-static solution or similar additive as this may scratch the screen's coating.
- Do not rub, touch, or tap the surface of the screen with sharp or abrasive items such as a ballpoint pen or screwdriver. This type of contact may result in a scratched picture tube.
- Clean the cabinet, panel and controls with a soft cloth lightly moistened with a mild detergent solution. Do not use any type of abrasive pad, scouring powder or solvent, such as alcohol or benzene.

#### Transportation

When you transport this monitor for repair or shipment, use the original carton and packing materials.

#### Use of the tilt-swivel

This monitor can be adjusted within the angles shown below. To find the center of the monitor's turning radius, align the center of the monitor's screen with the centering dots on the stand.

Hold the monitor at the bottom with both hands when you turn it horizontally or vertically. Be careful not to pinch your fingers at the back of the monitor when you tilt the monitor up vertically.

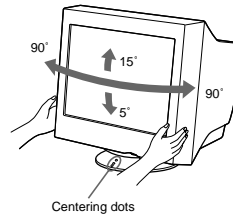

### Identifying parts and controls

See the pages in parentheses for further details.

#### Front

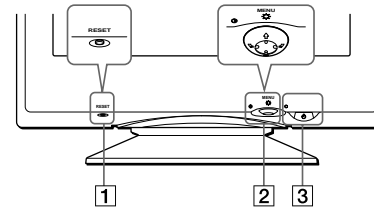

#### 1 RESET button (page 14)

This button resets the adjustments to the factory settings.

#### 2 Control button (page 9)

The control button is used to display the menu and make adjustments to the monitor, including brightness and contrast adjustments.

#### 3 (power) switch and indicator (pages 7, 15, 18)

This button turns the monitor on and off. The power indicator lights up in green when the monitor is turned on, and either flashes in green and orange, or lights up in orange when the monitor is in power saving mode.

#### Rear

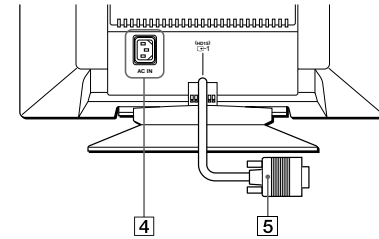

#### 4 AC IN connector (page 7)

This connector provides AC power to the monitor.

#### 5 Video input 1 connector (HD15) (page 6)

This connector inputs RGB video signals (0.700 Vp-p, positive) and sync signals.

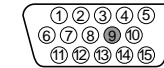

Pin No.	Signal
1	Red
2	Green (Sync on Green)
3	Blue
4	ID (Ground)
5	DDC Ground*
6	Red Ground
7	Green Ground
8	Blue Ground
9	—
10	Ground
11	ID (Ground)
12	Bi-Directional Data (SDA)*
13	H. Sync
14	V. Sync
15	Data Clock (SCL)*

\* DDC (Display Data Channel) is a standard of VESA.

US

## Setup

Before using your monitor, check that the following accessories are included in your carton:

- Power cord
- Current G3 adapter (for beige system) (1)
- Setup Disk (1)
- Warranty card
- Notes on cleaning the screen's surface
- This instruction manual

### Step 1: Connect your monitor to your computer

Turn off the monitor and computer before connecting.

#### Note

Do not touch the pins of the video signal cable connector as this might bend the pins.

#### ■ Connecting to an IBM PC/AT or compatible computer

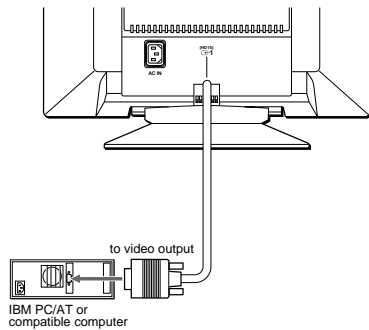

#### ■ Connecting to a Macintosh or compatible computer

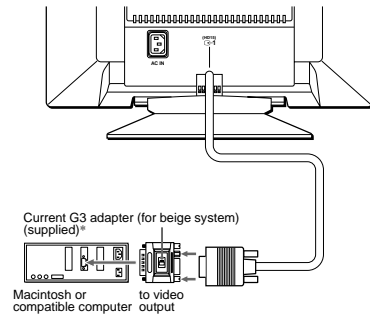

- \* Connect the supplied Macintosh adapter to the computer before connecting the cable. This adapter is compatible with Macintosh LC, Performa, Quadra, Power Macintosh, and Power Macintosh G3 series computers that have two rows of pins. If you are connecting to the other version of Power Macintosh G3 series with three rows of pins or models other than those stated above, you will need a different adapter (not supplied).

### Step 2: Connect the power cord

With the monitor and computer switched off, first connect the power cord to the monitor, then connect it to a power outlet.

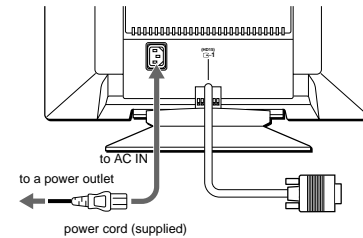

### Step 3: Turn on the monitor and computer

First turn on the monitor, then turn on the computer.

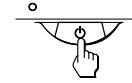

The installation of your monitor is complete. If necessary, use the monitor's controls to adjust the picture.

#### If no picture appears on your screen

- Check that the monitor is correctly connected to the computer.
- If NO INPUT SIGNAL appears on the screen, confirm that the video signal cable is properly connected and all plugs are firmly seated in their sockets.
- If MONITOR IS IN POWER SAVE MODE appeared on the screen, try pressing any key on the computer keyboard.
- If you are replacing an old monitor with this model and OUT OF SCAN RANGE appears on the screen, reconnect the old monitor. Then adjust the computer's graphic board so that the horizontal frequency is between 30 – 96 kHz, and the vertical frequency is between 48 – 120 Hz.

For more information about the on-screen messages, see "Trouble symptoms and remedies" on page 16.

US

#### Setup on various OS (Operating System)

This monitor complies with the "DDC" Plug & Play standard and automatically detects all the monitor's information with the Windows Plug & Play function. No specific driver needs to be installed to the computer.

If you connect the monitor to your PC, and then boot your PC for the first time, the setup Wizard may be displayed on the screen. Click on "Next" several times according to the instructions from the Wizard until the Plug & Play Monitor is automatically selected so that you can use this monitor. If your PC/graphics board has difficulty communicating with this monitor, load the supplied Setup Disk. Refer to the "Read Me" file on the Disk about the procedure to install. You can also download the information by accessing the web site of the graphics board's manufacturer.

#### For customers using Windows NT4.0

Monitor setup in Windows NT4.0 does not use the display driver. Refer to the Windows NT4.0 instruction manual for further details on adjusting the resolution, refresh rate, and number of colors.



## Selecting the on-screen menu language (LANG)

English, French, German, Spanish, Italian, Dutch, Swedish, Russian and Japanese versions of the on-screen menus are available. The default setting is English.

### 1 Press the center of the control button.

See page 9 for more information on using the control button.

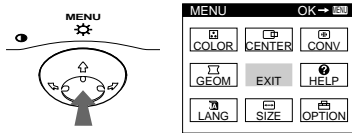

### 2 Move the control button to highlight LANG and press the center of the control button again.



### 3 Move the control button ↓/↑ to select a language.

- ENGLISH
- FRANÇAIS: French
- DEUTSCH: German
- ESPAÑOL: Spanish
- ITALIANO: Italian
- NEDERLANDS: Dutch
- SVENSKA: Swedish
- РУССКИЙ: Russian
- 日本語: Japanese

#### To close the menu

Press the center of the control button once to return to the main MENU, and twice to return to normal viewing. If no buttons are pressed, the menu closes automatically after about 30 seconds.

#### To reset to English

Press the RESET button while the LANGUAGE menu is displayed on the screen.

## Customizing Your Monitor

You can make numerous adjustments to your monitor using the on-screen menu.

### Navigating the menu

Press the center of the control button to display the main MENU on your screen. See page 9 for more information on using the control button.

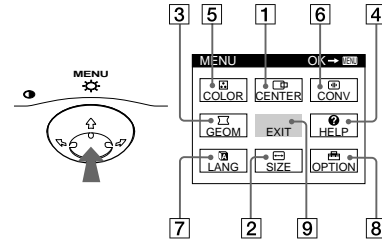

Use the control button to select one of the following menus.

#### 1 CENTER (page 10)

Selects the CENTER menu to adjust the picture's centering, size or zoom.

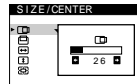

#### 2 SIZE (page 10)

Selects the SIZE menu to adjust the picture's size, centering or zoom.

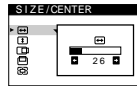

#### 3 GEOM (page 11)

Selects the GEOM menu to adjust the picture's rotation and shape.

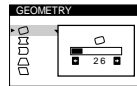

#### 4 HELP (page 13)

Selects the HELP menu to display helpful hints and information about this monitor.

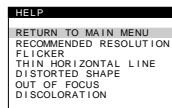

#### 5 COLOR (page 11)

Selects the COLOR menu to adjust the picture's color temperature. You can use this to match the monitor's colors to a printed picture's colors.

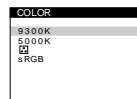

#### 6 CONV (page 12)

Selects the CONV menu to adjust the picture's horizontal and vertical convergence.

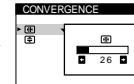

#### 7 LANG (page 8)

Selects the LANG menu to choose the on-screen menu's language.



#### 8 OPTION (page 12)

Selects the OPTION menu to adjust the monitor's options. The options include:

- degaussing the screen
- adjusting the moire cancellation level
- changing the on-screen menu position
- locking the controls

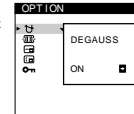

#### 9 EXIT

Select EXIT to close the menu.

### ■ Displaying the current input signal

The horizontal and vertical frequencies of the current input signal are displayed in the main MENU. If the signal matches one of this monitor's factory preset modes, the resolution is also displayed.

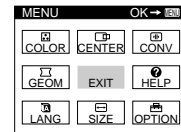

the resolution of the current input signal — (68.7kHz / 85Hz) (1024x768) — the horizontal and vertical frequencies of the current input signal

### ■ Using the control button

#### 1 Display the main MENU.

Press the center of the control button to display the main MENU on your screen.

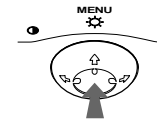

#### 2 Select the menu you want to adjust.

Highlight the desired menu by moving the control button towards the rear to go up (↑), towards the front to go down (↓), and left (←) or right (→) to move sideways.

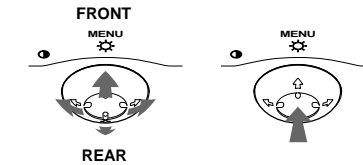

#### 3 Adjust the menu.

Move the control button left (←) or right (→) to make the adjustment.

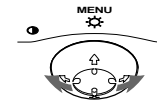

#### 4 Close the menu.

Press the center of the control button once to return to the main MENU, and twice to return to normal viewing. If no buttons are pressed, the menu closes automatically after about 30 seconds.

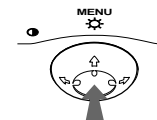

### ■ Resetting the adjustments

Press the RESET button. See page 14 for more information on resetting the adjustments.

#### RESET



## Adjusting the brightness and contrast

Brightness and contrast adjustments are made using a separate BRIGHTNESS/CONTRAST menu. These settings are stored in memory for all input signals.

### 1 Move the control button in any direction.

The BRIGHTNESS/CONTRAST menu appears on the screen.



### 2 Move the control button $\uparrow/\downarrow$ to adjust the brightness (☉), and $\leftarrow/\rightarrow$ to adjust the contrast (●).

The menu automatically disappears after about 3 seconds.

If you set sRGB to "ON" on the color setting, the brightness (☉) and contrast (●) are automatically set to "31" and "85" respectively.

For more information about sRGB, see "Adjusting the color of the picture (COLOR)" on page 11.

## Adjusting the centering of the picture (CENTER)

This setting is stored in memory for the current input signal.

### 1 Press the center of the control button.

The main MENU appears on the screen.

### 2 Move the control button to highlight $\square$ CENTER and press the center of the control button again.

The SIZE/CENTER menu appears on the screen.

### 3 First move the control button $\uparrow/\downarrow$ to select $\square$ for horizontal adjustment, or $\square$ for vertical adjustment. Then move the control button $\leftarrow/\rightarrow$ to adjust the centering.

## Adjusting the size of the picture (SIZE)

This setting is stored in memory for the current input signal.

### 1 Press the center of the control button.

The main MENU appears on the screen.

### 2 Move the control button to highlight $\square$ SIZE or $\square$ CENTER and press the center of the control button again.

The SIZE/CENTER menu appears on the screen.

### 3 First move the control button $\uparrow/\downarrow$ to select $\square$ for horizontal adjustment, or $\square$ for vertical adjustment. Then move the control button $\leftarrow/\rightarrow$ to adjust the size.

## Enlarging or reducing the picture (ZOOM)

This setting is stored in memory for the current input signal.

### 1 Press the center of the control button.

The main MENU appears on the screen.

### 2 Move the control button to highlight $\square$ SIZE or $\square$ CENTER and press the center of the control button again.

The SIZE/CENTER menu appears on the screen.

### 3 Move the control button $\uparrow/\downarrow$ to select $\square$ (zoom), and move $\leftarrow/\rightarrow$ to enlarge or reduce the picture.

#### Notes

- Adjustment stops when either the horizontal or vertical size reaches its maximum or minimum value.
- The horizontal adjustment value is not displayed in the menu.

## Adjusting the shape of the picture (GEOM)

The GEOM settings allow you to adjust the rotation and shape of the picture.

The  $\square$  (rotation) setting is stored in memory for all input signals. All other settings are stored in memory for the current input signal.

### 1 Press the center of the control button.

The main MENU appears on the screen.

### 2 Move the control button to highlight $\square$ GEOM and press the center of the control button again.

The GEOMETRY menu appears on the screen.

### 3 First move the control button $\uparrow/\downarrow$ to select the desired adjustment item. Then move the control button $\leftarrow/\rightarrow$ to make the adjustment.

Select	To
$\square$	rotate the picture
$\square$	expand or contract the picture sides
$\square$	shift the picture sides to the left or right
$\square$	adjust the picture width at the top of the screen
$\square$	shift the picture to the left or right at the top of the screen

## Adjusting the color of the picture (COLOR)

The COLOR settings allow you to adjust the picture's color temperature by changing the color level of the white color field. Colors appear reddish if the temperature is low, and bluish if the temperature is high. This adjustment is useful for matching the monitor's colors to a printed picture's colors. This setting is stored in memory for all input signals.

### 1 Press the center of the control button.

The main MENU appears on the screen.

### 2 Move the control button to highlight $\square$ COLOR and press the center of the control button again.

The COLOR menu appears on the screen.

### 3 Move the control button $\uparrow/\downarrow$ to select a color temperature.

The preset color temperatures are 5000K and 9300K. Since the default setting is 9300K, the whites will change from a bluish hue to a reddish hue as the temperature is lowered to 5000K.

### 4 If necessary, fine tune the color temperature.

You can select your own color temperature between 9300K and 5000K.

First move the control button  $\uparrow/\downarrow$  to select  $\square$ . Then move the control button  $\leftarrow/\rightarrow$  to adjust the color temperature.

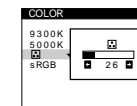

### sRGB Mode

The sRGB color setting is an industry standard color space protocol designed to correlate the displayed and printed colors of sRGB compliant computer products. To adjust the colors to the sRGB profile, simply set the sRGB "ON" in the COLOR menu. However, in order to display the sRGB colors correctly ( $\gamma=2.2$ , 6500K), you must set your computer to the sRGB profile.

When you set sRGB to "ON", the brightness (☉) and contrast (●) are automatically set to "31" and "85" respectively. If you change the brightness (☉) and contrast (●), sRGB setting is changed to "OFF."

For information on how to change the brightness (☉) and contrast (●), see page 10.

#### Note

Your computer and other connected products (such as a printer), must be sRGB compliant.

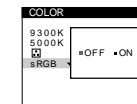



US

## Adjusting the convergence (CONV)

The CONV settings allow you to adjust the quality of the picture by controlling the convergence. The convergence refers to the alignment of the red, green, and blue color signals.

If you see red or blue shadows around letters or lines, adjust the convergence.

These settings are stored in memory for all input signals.

- 1 Press the center of the control button.**  
The main MENU appears on the screen.
- 2 Move the control button to highlight  CONV and press the center of the control button again.**  
The CONVERGENCE menu appears on the screen.
- 3 First move the control button  $\downarrow/\uparrow$  to select  for horizontal adjustment, or  for vertical adjustment. Then move the control button  $\leftarrow/\rightarrow$  to adjust the convergence.**

## Additional settings (OPTION)

You can manually degauss (demagnetize) the monitor, adjust the moire cancellation level, change the menu position, and lock the controls.

- 1 Press the center of the control button.**  
The main MENU appears on the screen.
- 2 Move the control button to highlight  OPTION and press the center of the control button again.**  
The OPTION menu appears on the screen.
- 3 Move the control button  $\downarrow/\uparrow$  to select the desired adjustment item.**  
Adjust the selected item according to the following instructions.

### Degaussing the screen

The monitor is automatically demagnetized (degaussed) when the power is turned on.

**To manually degauss the monitor, first move the control button  $\downarrow/\uparrow$  to select  (DEGAUSS). Then move the control button  $\rightarrow$ .**

The screen is degaussed for about 5 seconds. If a second degauss cycle is needed, allow a minimum interval of 20 minutes for the best result.

### Adjusting the moire\*

If elliptical or wavy patterns appear on the screen, adjust the moire cancellation level.

**To adjust the amount of moire cancellation, first move the control button  $\downarrow/\uparrow$  to select  (MOIRE ADJUST). Then move the control button  $\leftarrow/\rightarrow$  until the moire effect is at a minimum.**



\* Moire is a type of natural interference which produces soft, wavy lines on your screen. It may appear due to interference between the pattern of the picture on the screen and the phosphor pitch pattern of the monitor.

Example of moire







### Changing the menu's position

Change the menu's position if it is blocking an image on the screen.

**To change the menu's on-screen position, first move the control button  $\downarrow/\uparrow$  to select  (OSD H POSITION) for horizontal adjustment, or  (OSD V POSITION) for vertical adjustment. Then move the control button  $\leftarrow/\rightarrow$  to shift the on-screen menu.**

## Locking the controls

**To protect adjustment data by locking the controls, first move the control button  $\downarrow/\uparrow$  to select  (CONTROL LOCK). Then move the control button  $\rightarrow$ , to select ON.** Only the  (power) switch, EXIT, and  (CONTROL LOCK) of the OPTION menu will operate. If any other items are selected, the  mark appears on the screen.

### To cancel the control lock

Repeat the procedure above and set  (CONTROL LOCK) to OFF.

## Helpful hints and information (HELP)

The HELP menu contains helpful hints and information about this monitor. If your monitor is displaying symptoms that match those listed in the HELP menu, follow the on-screen instructions to resolve the problem. If the symptoms do not match those listed in the HELP menu or if the problem persists, see "Trouble symptoms and remedies" on page 16.

- 1 Press the center of the control button.**  
The main MENU appears on the screen.
- 2 Move the control button to highlight  HELP and press the center of the control button again.**  
The following HELP menu appears on the screen.

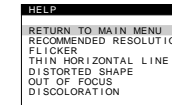

- 3 Move the control button  $\downarrow/\uparrow$  to select a HELP menu item and press the center of the control button again.**

Instructions or information to resolve the problem appears on the screen. An explanation of each menu item is given below.

### RECOMMENDED RESOLUTION

If the picture does not fill the screen to the edges or if the picture appears too large for the screen, adjust the resolution to the figures shown in the menu using your computer. If the input signal matches one of this monitor's factory preset modes, the resolution and refresh rate of the current input signal are displayed.

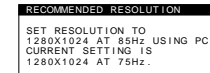

### FLICKER

If the picture is flickering, adjust the refresh rate to figures shown in the menu. If the input signal matches one of this monitor's factory preset modes, the refresh rate of the current input signal is displayed.

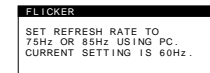

US

## THIN HORIZONTAL LINE

The lines that appear on your screen are damper wires. See page 15 for more information about the damper wires.

## DISTORTED SHAPE

If the shape of the picture on the screen seems distorted, try adjusting the picture's geometry. Move the control button  $\rightarrow$  to jump directly to the GEOMETRY menu.

## OUT OF FOCUS

The picture may seem to be out of focus when the red and blue color signals are not aligned properly, causing red or blue shadows to appear around letters and lines. Try adjusting the picture's convergence to make the shadows disappear. Move the control button  $\rightarrow$  to jump directly to the CONVERGENCE menu. When the CONVERGENCE menu is displayed, the contrast, brightness and moire adjustment settings are automatically reset for all input signals.

## DISCOLORATION

If the picture's color appears abnormal in certain areas of the screen, first check for any loose signal cables. After you have checked the cables, try degaussing (demagnetizing) the screen manually. Move the control button  $\rightarrow$  to jump directly to the OPTION menu, then select  $\updownarrow$  (DEGAUSS).

## Resetting the adjustments

This monitor has the following three reset methods. Use the RESET button to reset the adjustments.

### RESET



### Resetting a single adjustment item

Use the control button to select the adjustment item you want to reset, and press the RESET button.

### Resetting all of the adjustment data for the current input signal

Press the RESET button when no menu is displayed on the screen. Note that the following items are not reset by this method:

- on-screen menu language (page 8)
- on-screen menu position (page 12)
- control lock (page 13)

### Resetting all of the adjustment data for all input signals

Press and hold the RESET button for more than two seconds.

#### Note

The RESET button does not function when  $\bullet$  (CONTROL LOCK) is set to ON.

## Technical Features

### Preset and user modes

When the monitor receives an input signal, it automatically matches the signal to one of the factory preset modes stored in the monitor's memory to provide a high quality picture at the center of the screen. (See Appendix for a list of the factory preset modes.) For input signals that do not match one of the factory preset modes, the digital Multiscan technology of this monitor ensures that a clear picture appears on the screen for any timing in the monitor's frequency range (horizontal: 30 – 96 kHz, vertical: 48 – 120 Hz). If the picture is adjusted, the adjustment data is stored as a user mode and automatically recalled whenever the same input signal is received.

#### Note for Windows users

For Windows users, check your video board manual or the utility program which comes with your graphic board and select the highest available refresh rate to maximize monitor performance.

### Power saving function

This monitor meets the power-saving guidelines set by VESA, ENERGY STAR, and NUTEK. If the monitor is connected to a computer or video graphics board that is DPMS (Display Power Management Signaling) compliant, the monitor will automatically reduce power consumption in three stages as shown below.

Power mode	Power consumption	(power) indicator
normal operation	≤ 140 W	green
1 standby	≤ 15 W	green and orange alternate
2 suspend (sleep)*	≤ 15 W	green and orange alternate
3 active off** (deep sleep)*	≤ 3 W	orange
power off	0 W	off

\* "Sleep" and "deep sleep" are power saving modes defined by the Environmental Protection Agency.

\*\* When your computer is in a power saving mode, MONITOR IS IN POWER SAVE MODE appears on the screen if you press any button on the monitor. After a few seconds, the monitor enters the power saving mode again.

## Troubleshooting

Before contacting technical support, refer to this section.

### If thin lines appear on your screen (damper wires)

The lines you are experiencing on your screen are normal for the Trinitron monitor and are not a malfunction. These are shadows from the damper wires used to stabilize the aperture grille and are most noticeable when the screen's background is light (usually white). The aperture grille is the essential element that makes a Trinitron picture tube unique by allowing more light to reach the screen, resulting in a brighter, more detailed picture.

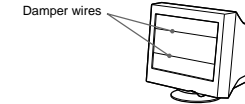

### On-screen messages

If no picture appears on the screen, one of the following messages appears on the screen. To solve the problem, see "Trouble symptoms and remedies" on page 16.

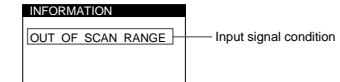

#### The input signal condition OUT OF SCAN RANGE

indicates that the input signal is not supported by the monitor's specifications.

#### NO INPUT SIGNAL





indicates that no signal is input.

#### MONITOR IS IN POWER SAVE MODE

indicates that the computer is in power saving mode. This message is displayed only when your computer is in a power saving mode and you press any one of the buttons on the monitor.

## Trouble symptoms and remedies

If the problem is caused by the connected computer or other equipment, please refer to the connected equipment's instruction manual. Use the self-diagnosis function (page 18) if the following recommendations do not resolve the problem.

Symptom	Check these items
<b>No picture</b>	
If the  (power) indicator is not lit	<ul style="list-style-type: none"> <li>Check that the power cord is properly connected.</li> <li>Check that the  (power) switch is in the "on" position.</li> </ul>
If the NO INPUT SIGNAL message appears on the screen, or if the  (power) indicator is either orange or alternating between green and orange	<ul style="list-style-type: none"> <li>Check that the video signal cable is properly connected and all plugs are firmly seated in their sockets (page 6).</li> <li>Check that the HD15 video input connector's pins are not bent or pushed in.</li> </ul> <p><b>■Problems caused by the connected computer or other equipment</b></p> <ul style="list-style-type: none"> <li>Check that the computer's power is "on."</li> <li>Check that the graphic board is completely seated in the proper bus slot.</li> </ul>
If the MONITOR IS IN POWER SAVE MODE message appears on the screen, or if the  (power) indicator is either orange or alternating between green and orange	<p><b>■Problems caused by the connected computer or other equipment</b></p> <ul style="list-style-type: none"> <li>The computer is in power saving mode. Try pressing any key on the computer keyboard.</li> <li>Check that the computer's power is "on."</li> <li>Check that the graphic board is completely seated in the proper bus slot.</li> </ul>
If the OUT OF SCAN RANGE message appears on the screen	<p><b>■Problems caused by the connected computer or other equipment</b></p> <ul style="list-style-type: none"> <li>Check that the video frequency range is within that specified for the monitor. If you replaced an old monitor with this monitor, reconnect the old monitor and adjust the frequency range to the following. Horizontal: 30 – 96 kHz Vertical: 48 – 120 Hz</li> </ul>
If no message is displayed and the  (power) indicator is green or flashing orange	<ul style="list-style-type: none"> <li>Use the Self-diagnosis function (page 18).</li> </ul>
If using Windows 95/98	<ul style="list-style-type: none"> <li>If you replaced an old monitor with this monitor, reconnect the old monitor and do the following. Install the supplied Setup Disk (page 7) and select this monitor ("CPD-E400") from among the Sony monitors in the Windows 95/98 monitor selection screen.</li> </ul>
If using a Macintosh system	<ul style="list-style-type: none"> <li>Check that the Macintosh adapter and the video signal cable are properly connected (page 6).</li> </ul>
<b>Picture flickers, bounces, oscillates, or is scrambled</b>	<ul style="list-style-type: none"> <li>Isolate and eliminate any potential sources of electric or magnetic fields such as other monitors, laser printers, electric fans, fluorescent lighting, or televisions.</li> <li>Move the monitor away from power lines or place a magnetic shield near the monitor.</li> <li>Try plugging the monitor into a different AC outlet, preferably on a different circuit.</li> <li>Try turning the monitor 90° to the left or right.</li> </ul> <p><b>■Problems caused by the connected computer or other equipment</b></p> <ul style="list-style-type: none"> <li>Check your graphics board manual for the proper monitor setting.</li> <li>Confirm that the graphics mode (VESA, Macintosh 16" Color, etc.) and the frequency of the input signal are supported by this monitor (Appendix). Even if the frequency is within the proper range, some video boards may have a sync pulse that is too narrow for the monitor to sync correctly.</li> <li>Adjust the computer's refresh rate (vertical frequency) to obtain the best possible picture.</li> </ul>
<b>Picture is fuzzy</b>	<ul style="list-style-type: none"> <li>Adjust the brightness and contrast (page 10).</li> <li>Degauss the monitor* (page 12).</li> <li>Select MOIRE ADJUST and adjust the moire cancellation effect (page 12).</li> </ul>

Symptom	Check these items
<b>Picture is ghosting</b>	<ul style="list-style-type: none"> <li>Eliminate the use of video cable extensions and/or video switch boxes.</li> <li>Check that all plugs are firmly seated in their sockets.</li> </ul>
<b>Picture is not centered or sized properly</b>	<ul style="list-style-type: none"> <li>Adjust the size (page 10) or centering (page 10). Note that some video modes do not fill the screen to the edges.</li> </ul>
<b>Edges of the image are curved</b>	<ul style="list-style-type: none"> <li>Adjust the geometry (page 11).</li> </ul>
<b>Wavy or elliptical pattern (moire) is visible</b>	<ul style="list-style-type: none"> <li>Select MOIRE ADJUST and adjust the moire cancellation effect (page 12).</li> </ul> <p><b>■Problems caused by the connected computer or other equipment</b></p> <ul style="list-style-type: none"> <li>Change your desktop pattern.</li> </ul>
<b>Color is not uniform</b>	<ul style="list-style-type: none"> <li>Degauss the monitor* (page 12). If you place equipment that generates a magnetic field, such as a speaker, near the monitor, or if you change the direction the monitor faces, color may lose uniformity.</li> </ul>
<b>White does not look white</b>	<ul style="list-style-type: none"> <li>Adjust the color temperature (page 11).</li> </ul>
<b>Letters and lines show red or blue shadows at the edges</b>	<ul style="list-style-type: none"> <li>Adjust the convergence (page 12).</li> </ul>
<b>Monitor buttons do not operate (O-m appears on the screen)</b>	<ul style="list-style-type: none"> <li>If the control lock is set to ON, set it to OFF (page 13).</li> </ul>
<b>A hum is heard right after the power is turned on</b>	<ul style="list-style-type: none"> <li>This is the sound of the auto-degauss cycle. When the power is turned on, the monitor is automatically degaussed for five seconds.</li> </ul>

\* If a second degauss cycle is needed, allow a minimum interval of 20 minutes for the best result. A humming noise may be heard, but this is not a malfunction.

### Displaying this monitor's name, serial number, and date of manufacture.

While the monitor is receiving a video signal, press and hold the center of the control button for more than five seconds to display this monitor's information box.

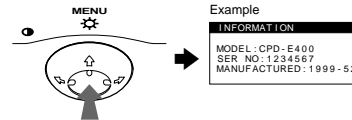



If the problem persists, call your authorized Sony dealer and give the following information.

- Model name: CPD-E400
- Serial number
- Name and specifications of your computer and graphics board.

US

## Self-diagnosis function

This monitor is equipped with a self-diagnosis function. If there is a problem with your monitor or computer, the screen will go blank and the  (power) indicator will either light up green or flash orange. If the  (power) indicator is lit in orange, the computer is in power saving mode. Try pressing any key on the keyboard.

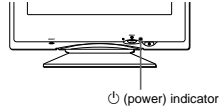

### If the (power) indicator is green

- 1 **Disconnect the video input cable or turn off the connected computer.**
- 2 **Press the  (power) button twice to turn the monitor off and then on.**
- 3 **Move the control button  $\Rightarrow$  for 2 seconds before the monitor enters power saving mode.**

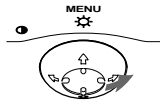



If all four color bars appear (white, red, green, blue), the monitor is working properly. Reconnect the video input cable and check the condition of your computer.

If the color bars do not appear, there is a potential monitor failure. Inform your authorized Sony dealer of the monitor's condition.

### If the (power) indicator is flashing orange

**Press the  (power) button twice to turn the monitor off and then on.**

If the  (power) indicator lights up green, the monitor is working properly.

If the  (power) indicator is still flashing, there is a potential monitor failure. Count the number of seconds between orange flashes of the  (power) indicator and inform your authorized Sony dealer of the monitor's condition. Be sure to note the model name and serial number of your monitor. Also note the make and model of your computer and video board.

## Specifications

CRT	0.24 mm aperture grille pitch (center) 19 inches measured diagonally 90-degree deflection FD Trinitron
Viewable image size	Approx. 365 × 274 mm (w/h) (14 <sup>3</sup> / <sub>8</sub> × 10 <sup>7</sup> / <sub>8</sub> inches) 18.0" viewing image
Resolution	Maximum Horizontal: 1800 dots Vertical: 1440 lines Recommended Horizontal: 1280 dots Vertical: 1024 lines
Standard image area	Approx. 352 × 264 mm (w/h) (13 <sup>7</sup> / <sub>8</sub> × 10 <sup>1</sup> / <sub>2</sub> inches)
Deflection frequency*	Horizontal: 30 to 96 kHz Vertical: 48 to 120 Hz
AC input voltage/current	100 to 240 V, 50 – 60 Hz, Max. 2.0 A
Power consumption	140 W
Operating temperature	10°C to 40°C
Dimensions	Approx. 446 × 464 × 461 mm (w/h/d) (17 <sup>5</sup> / <sub>8</sub> × 18 <sup>3</sup> / <sub>8</sub> × 18 <sup>1</sup> / <sub>4</sub> inches)
Mass	Approx. 26 kg (57 lb 5 oz)
Plug and Play	DDC1/DDC2B/DDC2Bi/GTF
Supplied accessories	See page 6

- \* Recommended horizontal and vertical timing condition
- Horizontal sync width should be more than 1.0 μsec.
  - Horizontal blanking width should be more than 3.0 μsec.
  - Vertical blanking width should be more than 500 μsec.

Design and specifications are subject to change without notice.

## SECTION 2 DISASSEMBLY

### 2-1. CABINET REMOVAL

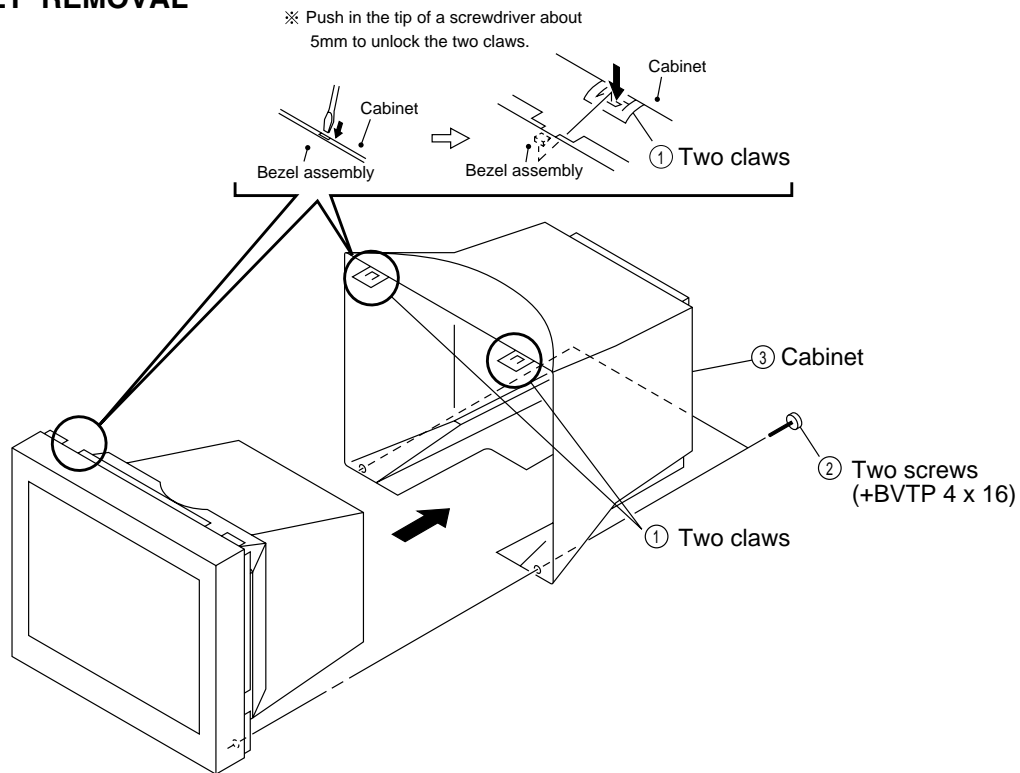

### 2-2. SHIELD (EMI, VIDEO), SIDE COVER (L and R) REMOVAL

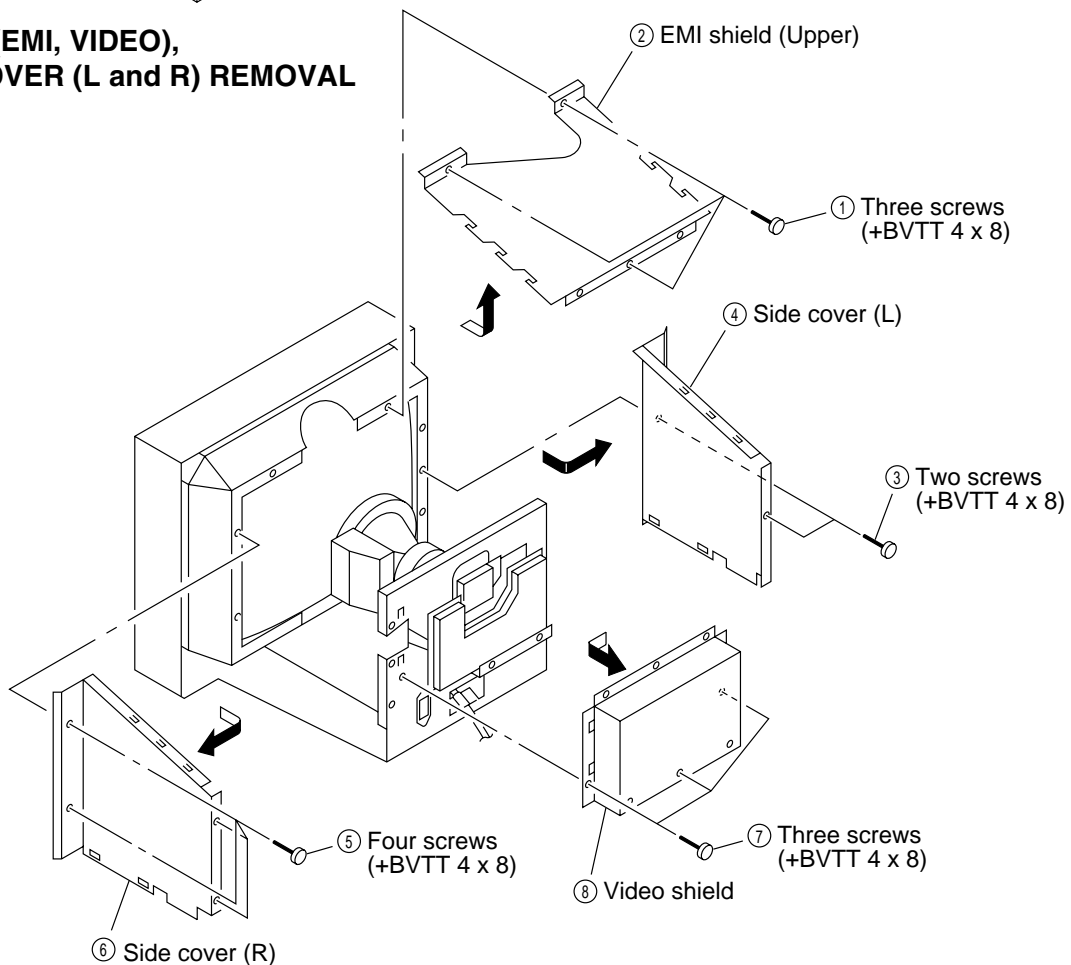

**2-3. A BOARD REMOVAL**

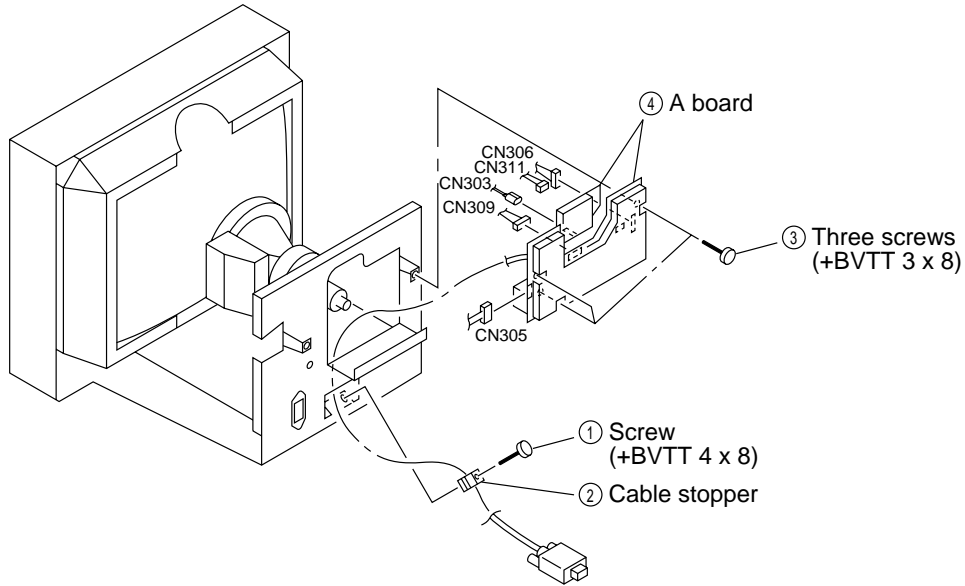

**2-4. REAR SHIELD COMPLETE ASSY, D BOARD REMOVAL**

※ Referring to 2-3, disconnect five connectors (CN303, CN305, CN306, CN309 and CN311).

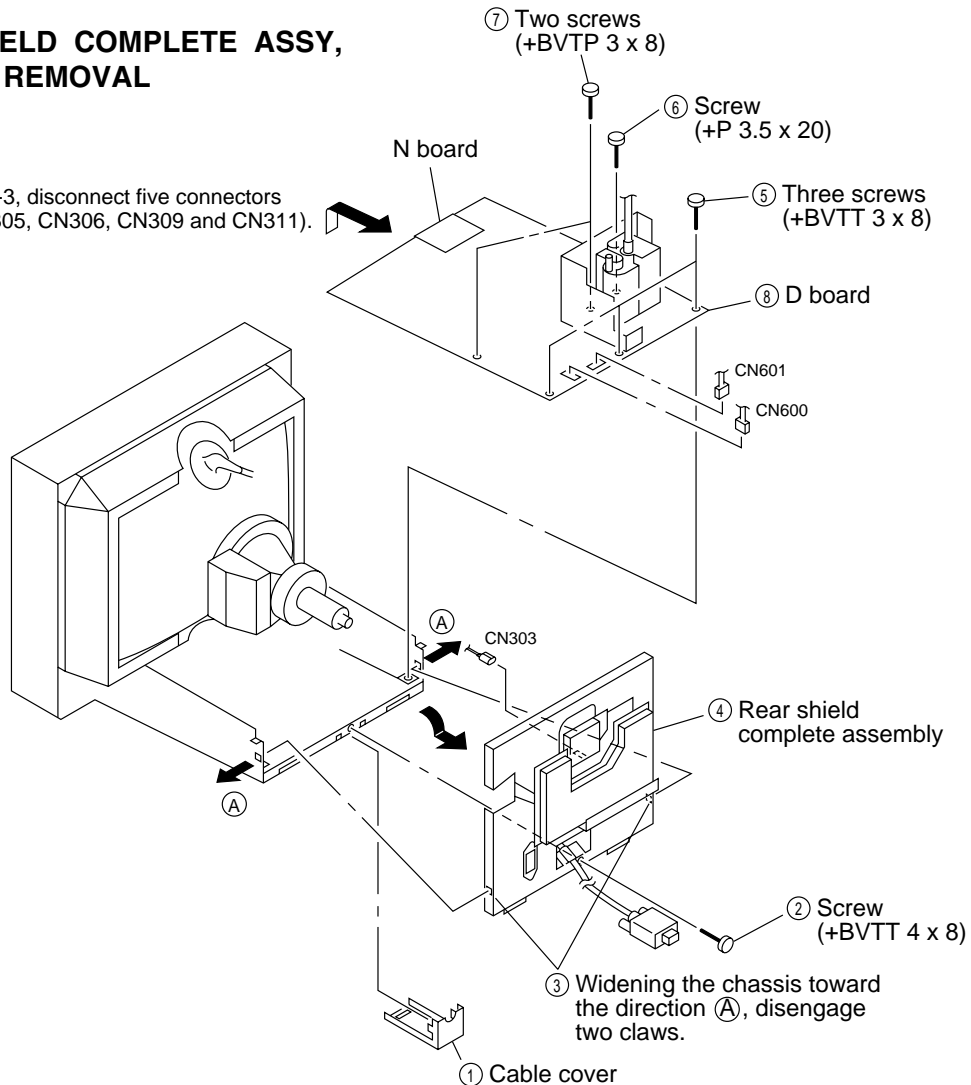



2-5. SERVICE POSITION

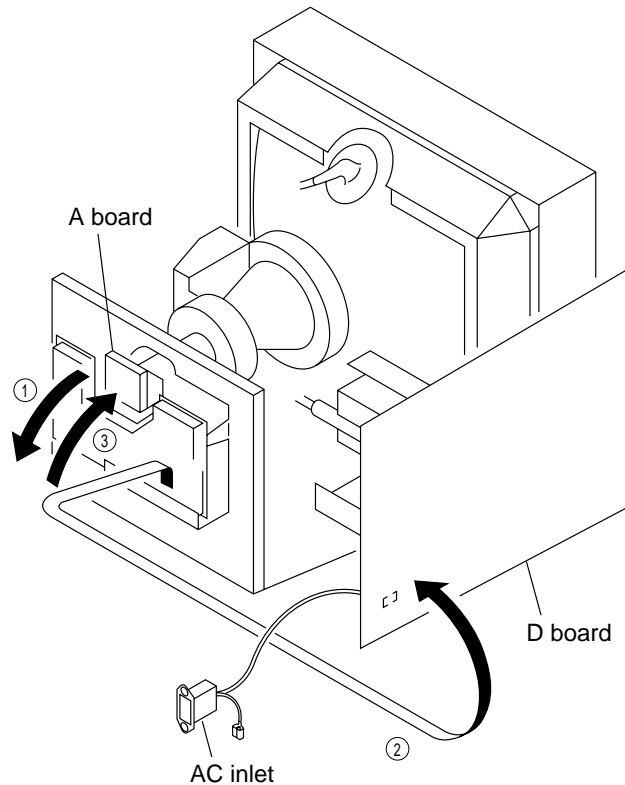

2-6. H BOARD REMOVAL

① Before removing the bezel assembly, secure the picture tube shield at the positions shown with the arrow (diagonal two places) to prevent the picture tube from falling. (Use the screws +BVTT 4×8 that fix shield.)

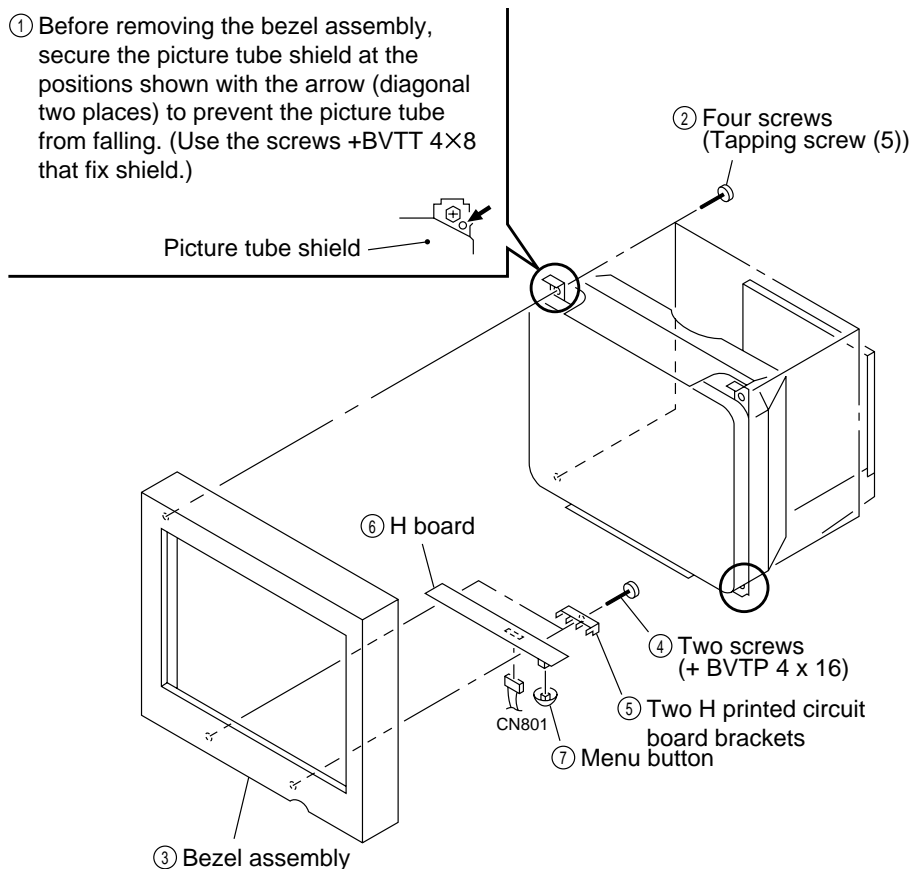

## 2-7. PICTURE TUBE REMOVAL

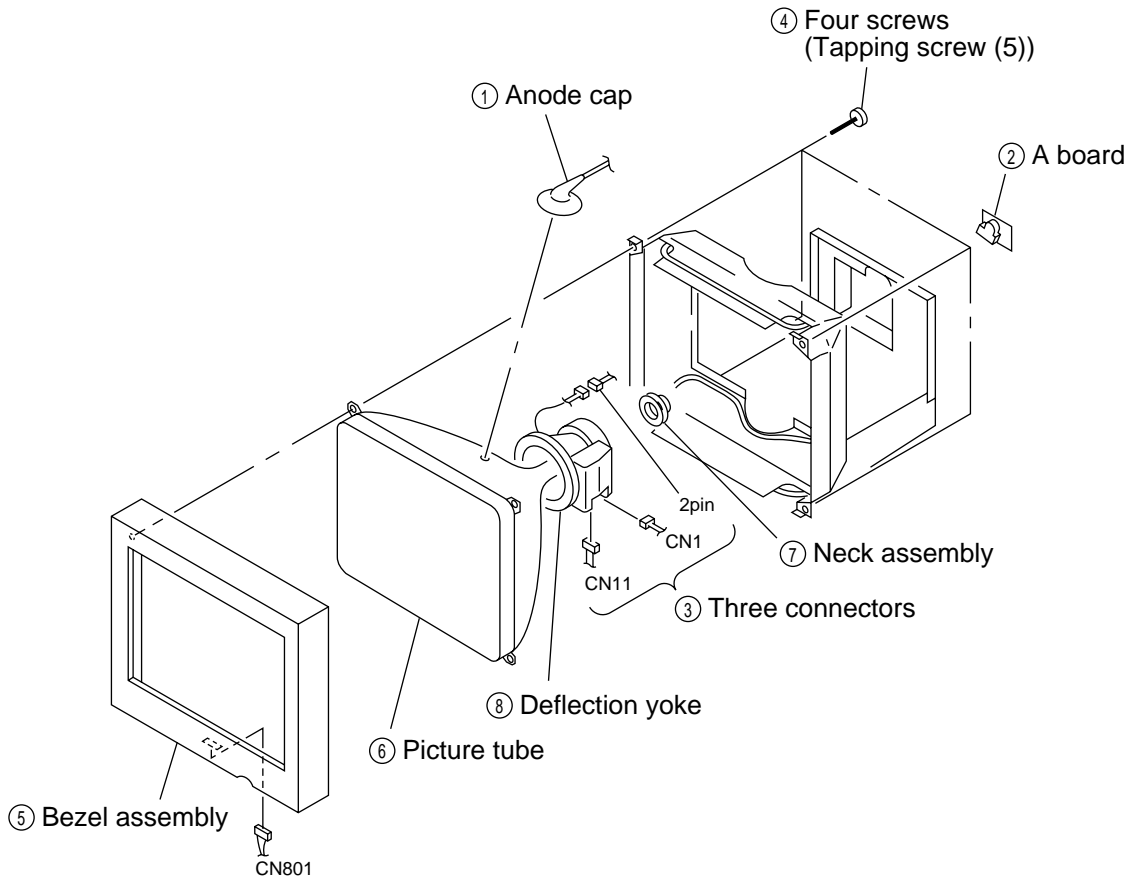

### • REMOVAL OF ANODE-CAP

NOTE: Short circuit the anode of the picture tube and the anode cap to the metal chassis, CRT shield or carbon painted on the CRT, after removing the anode.

### • REMOVING PROCEDURES

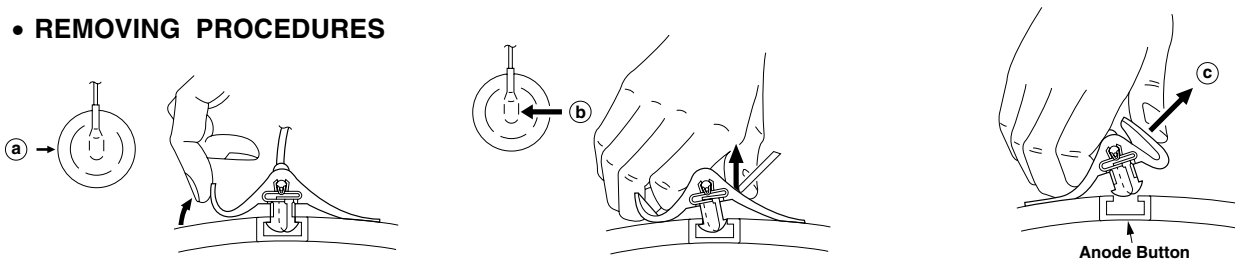

- ① Turn up one side of the rubber cap in the direction indicated by the arrow (a).
- ② Using a thumb pull up the rubber cap firmly in the direction indicated by the arrow (b).
- ③ When one side of the rubber cap is separated from the anode button, the anode-cap can be removed by turning up the rubber cap and pulling up it in the direction of the arrow (c).

### • HOW TO HANDLE AN ANODE-CAP

- ① Don't scratch the surface of anode-caps with sharp shaped material!
- ② Don't press the rubber hardly not to damage inside of anode-caps!  
A material fitting called as shatter-hook terminal is built in the rubber.
- ③ Don't turn the foot of rubber over hardly!  
The shatter-hook terminal will stick out or damage the rubber.

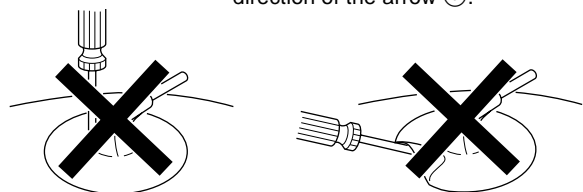

2-8. HARNESS LOCATION

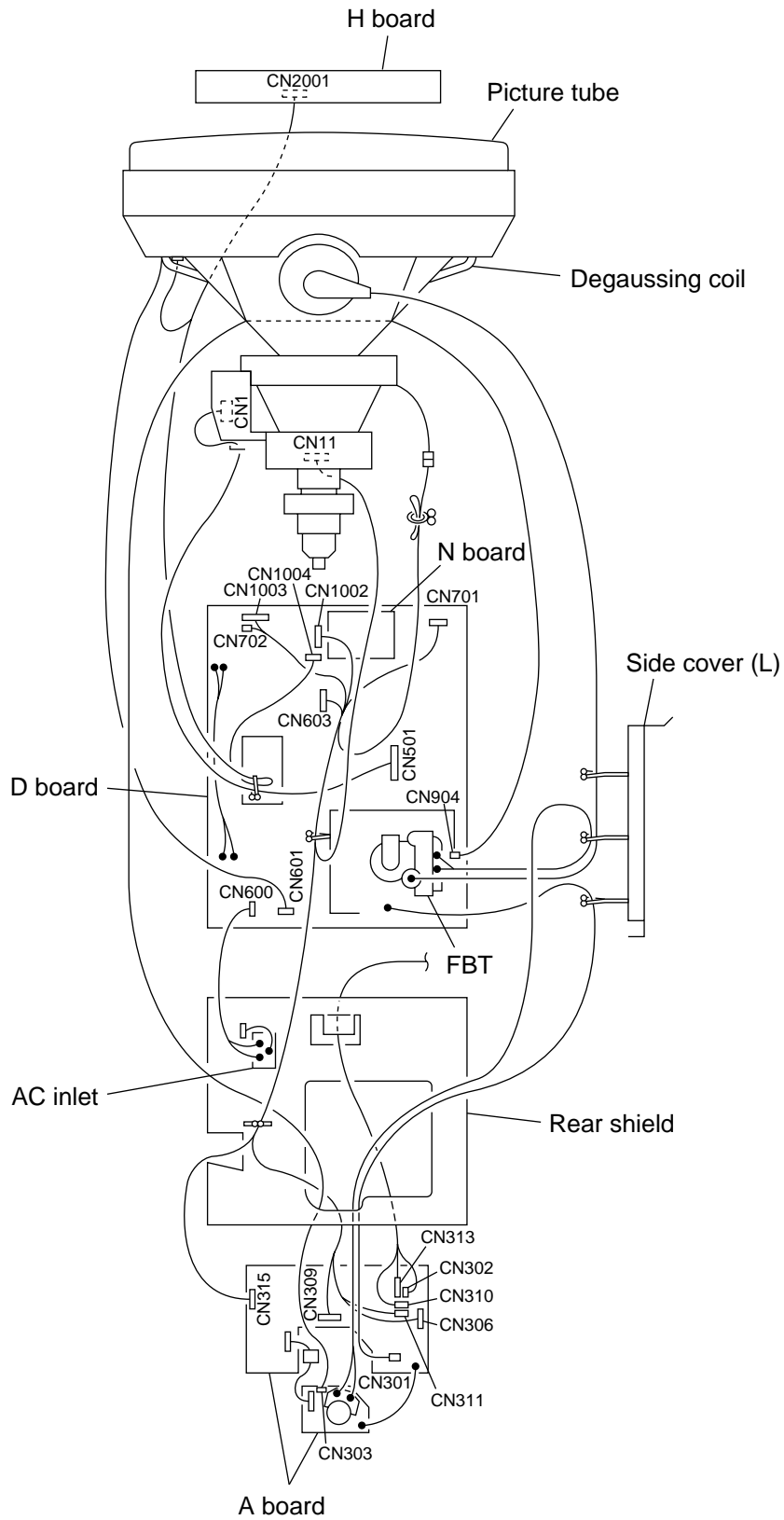

**SECTION 3**

**SAFETY RELATED ADJUSTMENT**

When replacing or repairing the shown below table, the following operational checks must be performed as a safety precaution against X-rays emissions from the unit.

	Part Replaced (☒)
HV ADJ	RV901

	Part Replaced (☑)
HV Regulator Circuit Check	D Board T901(FBT), IC901, R924, R925, RV901 • Mounted D board
HV Protector Circuit Check	D Board T901(FBT), R917, R918, R923, R920, R919, R1004, C920, D911, R912, • Mounted D board
Beam Current Protector Circuit Check	D Board R933, R932, R921, R1006, D915, D917, IC901, T901(FBT) • Mounted D board

\* Confirm one minute after turning on the power.

**a) High Voltage Adjustment**

- 1) Adjust the high voltage  $27.0 \text{ kV} \pm 0.2 \text{ kV}$  by the RV901.

Note: Perform high voltage adjustment after the rough adjustments were completed on PICTURE size and FOCUS.

**b) High Voltage Hold-Down Function Check**

- 1) Apply the voltage  $21.1^{+0.00}_{-0.05}$  VDC between D912 cathode and GND shown on the right to confirm that the RASTER will vanish.

**c) Beam Current Protector Function Check**

- 1) Connect Power Supply 1.68 mA to between pin 11 ~ GND of FBT (T901).
- 2) Confirm that voltage on C922 (ABL DET.) is less than 2.25 V or monitor will shut down.

**d) OCP Function Check**

- 1) Turn ON Power Supply.
- 2) Connect  $3 \Omega/20 \text{ W}$  of Resistor between +200 V Line and GND, and make sure that OCP will function (Power LED will vanish and the sound “chi,chi,chi will be heard.), and cut-off AC input promptly.

**e) Power Supply Operation Check**

- 1) Apply AC100 V to the D Board.
- 2) Make sure that the line voltage at the both ends of C621 is  $200 \pm 3.0 \text{ VDC}$ .

## SECTION 4 ADJUSTMENTS

• **Landing Rough Adjustment**

1. Enter the full white signal. (or the full black dots signal).
  2. Adjust the contrast to the maximum.
  3. Make the screen monogreen.
- Note: Off the outputs from R ch and B ch of SG.
4. Reverse the DY, and adjust coarsely the purity magnet so that a green raster positions in the center of screen.
  5. Moving the DY forward, adjust so that an entire screen becomes monogreen.
  6. Adjust the tilt of DY. For the TILT component, use TLV of DY.

Note: Observe the following adjustment conditions:

- “TILT” = 0
- “VPIN SAW TOP” = 0
- “VPIN SAW BTM” = 0

7. Lock the DY lightly with a locking fitting.

• **Landing Fine Adjustment**

<Landing adjustment conditions>

- a) Brightness: 1/3 Σ IK (Σ IK = 750 μA)
- b) Aging time: 2 hours or more.
- c) Atmospheric temperature: 25 °C
- d) magnetic Field:
  - BH = 0 ± 2 μT
  - BV = 45 ± 2 μT (U/C, AEP)
  - 55 ± 2 μT (South Hemisphere)
  - 10 ± 2 μT (Equator destination)
- e) Adjustment point:
  - 1-inch inside from the edge of CRT effective tube surface.
  1. Put the set inside the Helmholtz coil.
  2. Set the TLH plate to “0” position.
  3. Set the purity magnet of Neck Assy in “0” position, and lock with a white pen.
  4. Set “VPIN SAW TOP” and “VPIN SAW BTM” to “0” position.
  5. Receive an image of the monogreen signal.
  6. Degauss the CRT and iron shield parts.

Note: Iron bottom chassis and EMI shield should be degaussed before assembling the chassis.

7. Perform auto degaussing.
8. Attach the wobbling coil to the designated part of the CRT neck.
9. Attach the sensor of the landing adjustment unit on the CRT surface.
10. Adjust the DY position and purity, and the DY tilt.

Note: Use purity magnet on the DY.

11. Fasten DY with screw.

Note: Torque 22 ± 2 kg•cm (2.2 ± 0.2 Nm).

12. Perform auto degaussing.

13. Using two wedges, adjust vertical pins so as to attain a=b as shown below. Further, insert two wedges as shown in the right figure, and lock the center so that DY does not fluctuate horizontally.

Note: Insert wedges completely so that the DY does not move.

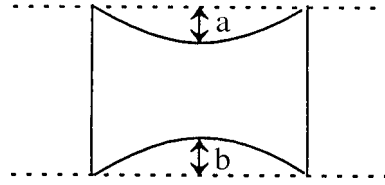

14. If the corner landing is out of the specification, use the landing magnet so as to satisfy the specification.

<Specification>

a) Green	x ± 4	x ± 7.5	x ± 4
	x ± 4	x ± 7.5	x ± 4
	x ± 4	x ± 7.5	x ± 4

[X] is bias value for a difference caused depending on whether the EMI shield and rear cover are present or not.

J Models : x = 1.5 [μm]

- b) Difference between Green and Red, and between Green and Blue.

± 5	± 5	± 5	
± 5	± 5	± 5	
± 5	± 5	± 5	[μm]

- c) Difference Red and Blue.

± 8	± 8	± 8	
± 8	± 7	± 8	
± 8	± 8	± 8	[μm]

Note:

- (1) Do not paste more than two magnets on one corner.
  - (2) Magnets will be placed in a range of 80 ~ 120 mm from the DY along the diagonal lines.
15. After placing magnets, absolutely degauss and check the results.

16. Remove the sensor and wobbling coil.

17. Check that the DY is not tilting, and fix the purity Mg with a white pen.

<RTV and wedge position>

- (1) Apply RTV to the shaded portions.
- (2) Lock CRT, wedges, and DY with RTV.

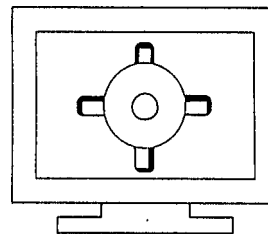

[Rear view]

Connect the communication cable of the computer to the connector located on the D board on the monitor. Run the service software and then follow the instruction.

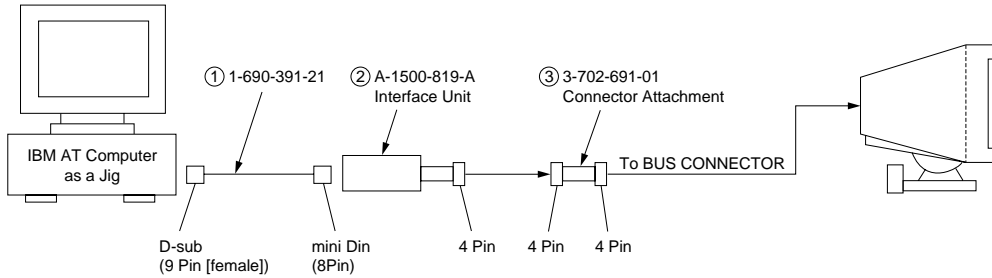

\*The parts above (1) ~ (3) are necessary for DAS adjustment.

**• Convergence Rough Adjustment**

- (1) Receive an image of the white crosshatch signals (white lines on black).
- (2) Make rough adjustment of the H and V direction convergence by using 4-fold poles magnet.
- (3) Make rough adjustment of the HMC and VMC by using 6-fold poles magnet.

<“0” position of each magnet and TLH plate>

- a) Align the protrusion marked with an arrow.

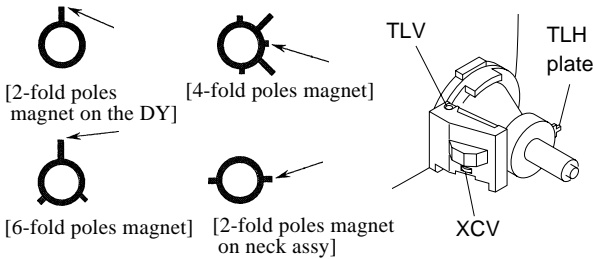

- b) Flush the shaded portions of TLH plate with the DY rear cover, as shown below.

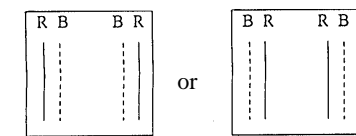
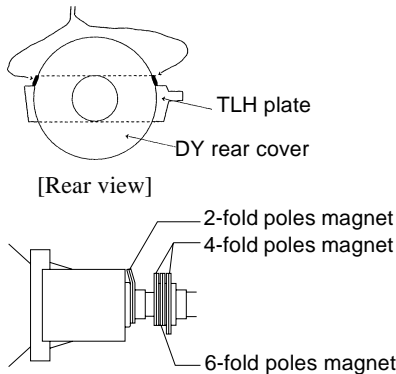

[Movements of TLH plate]

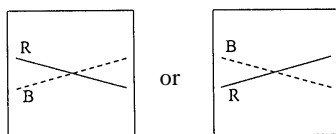

[Movements of XCV volume]

**• Convergence Specification**

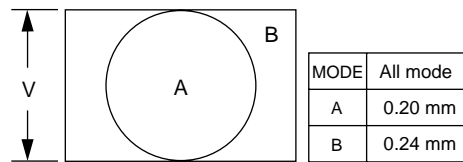

**• White Balance Adjustment Specification**

1. 9300 K  
 $x = 0.283 \pm 0.005$   
 $y = 0.298 \pm 0.005$   
 (All White)
2. 5000 K  
 $x = 0.346 \pm 0.005$   
 $y = 0.359 \pm 0.005$   
 (All White)
3. sRGB  
 $x = 0.313 \pm 0.005$   
 $y = 0.329 \pm 0.005$   
 (All White)

**• Vertical and Horizontal Position and Size Specification**

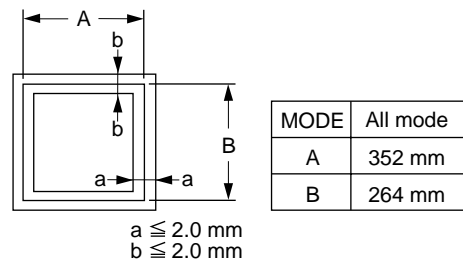

**• Focus adjustment**

Adjust the focus volume 1 and 2 for the optimum focus.

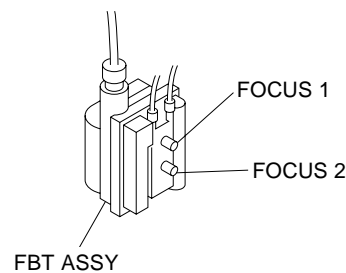

# SECTION 5 DIAGRAMS

## 5-1. BLOCK DIAGRAMS

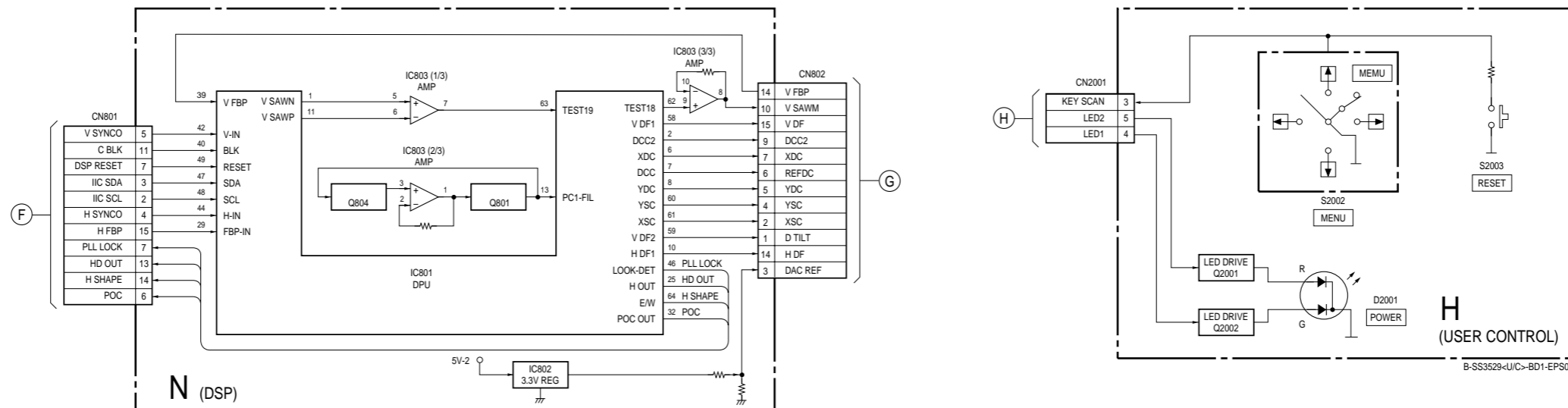
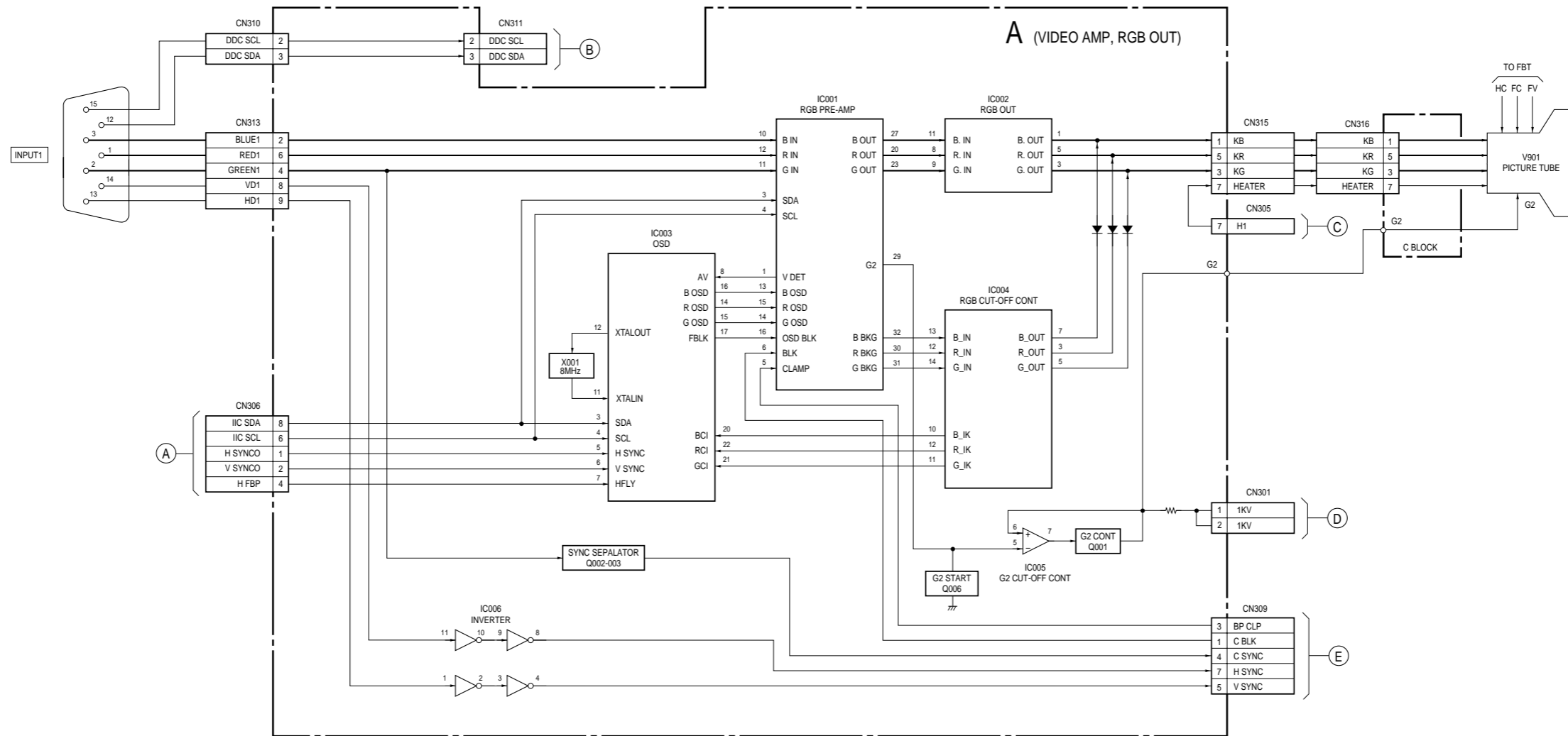

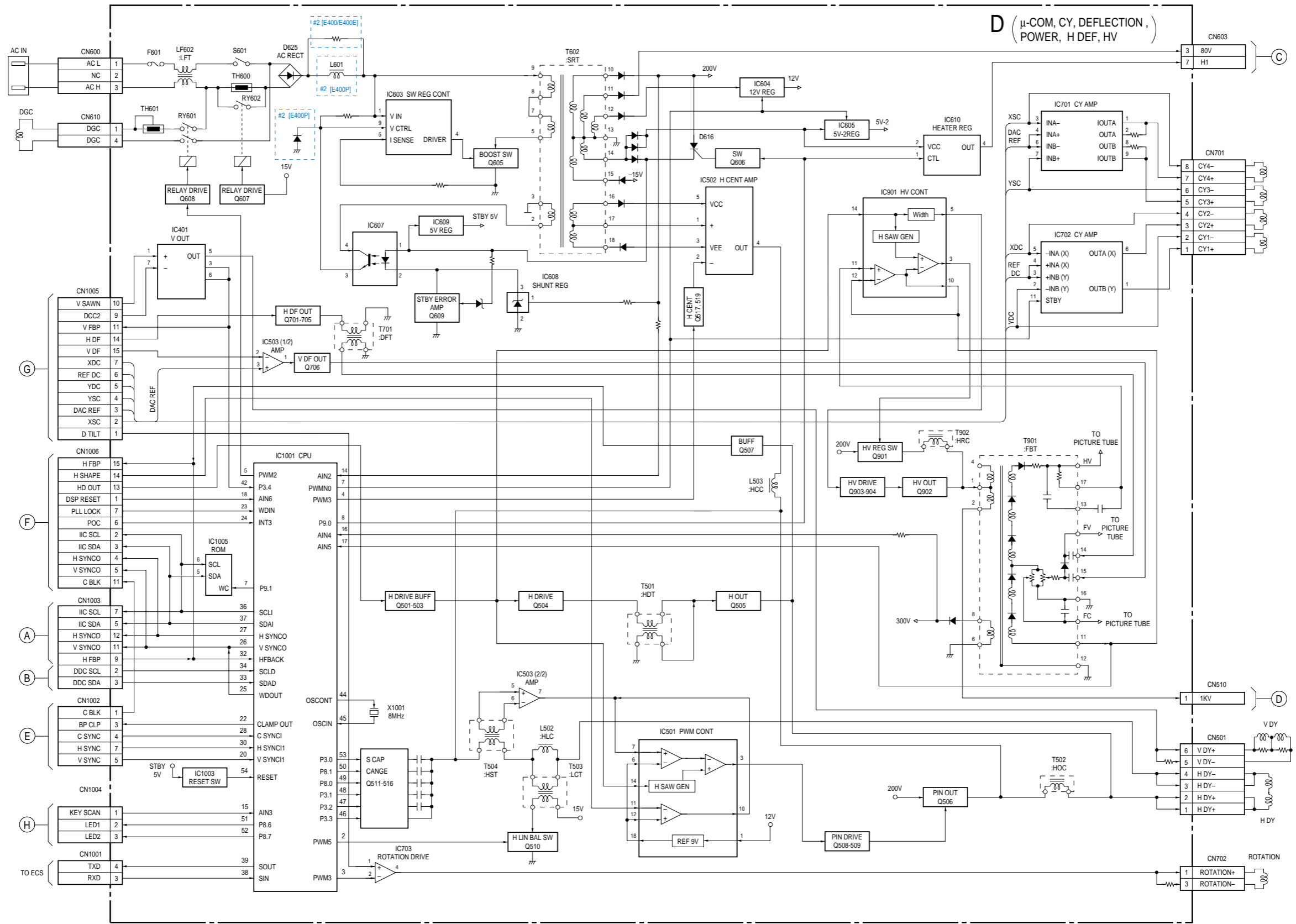

B-SS3547-AEP>BD2-EPS05



5-2. FRAME SCHEMATIC DIAGRAM

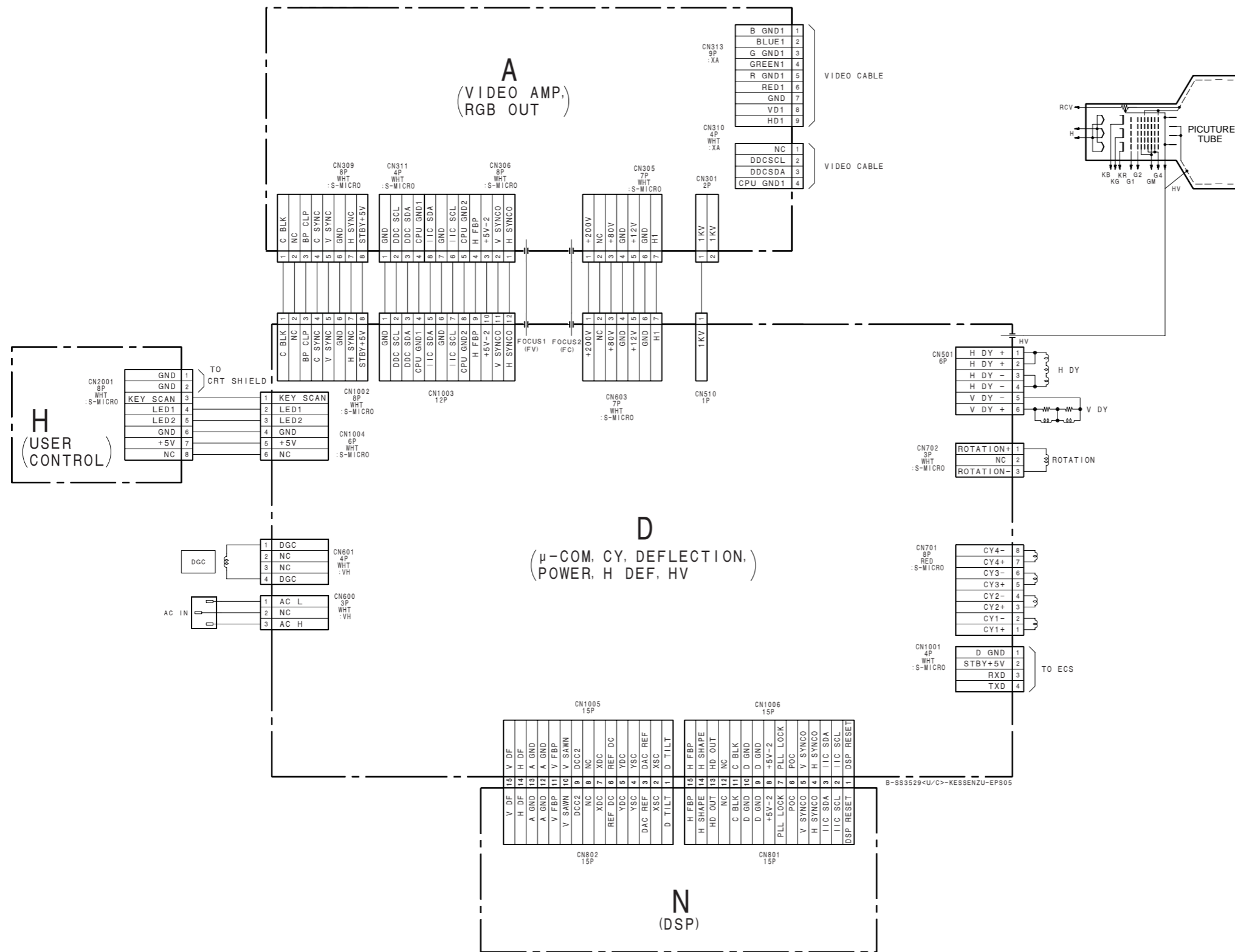

5-3. CIRCUIT BOARDS LOCATION

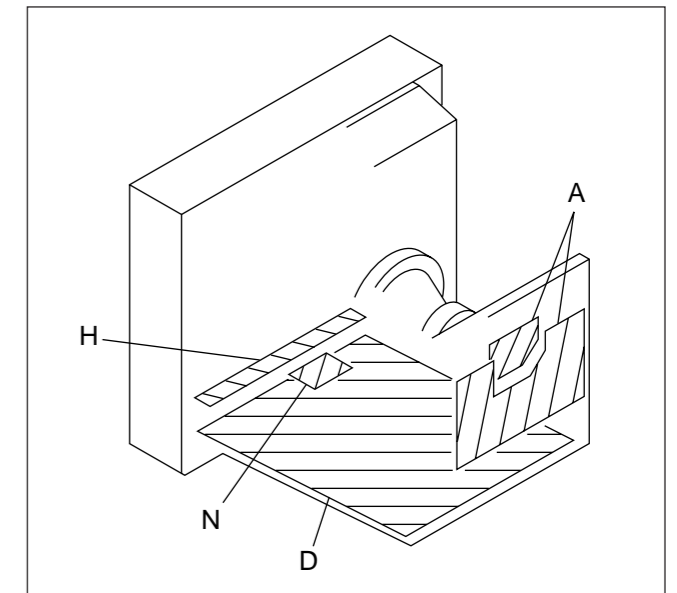

## 5-4. SCHEMATIC DIAGRAMS AND PRINTED WIRING BOARDS

### Note:

- All capacitors are in  $\mu\text{F}$  unless otherwise noted. ( $\text{pF}$ :  $\mu\text{F}$ )
- Capacitors without voltage indication are all 50 V.
- Indication of resistance, which does not have one for rating electrical power, is as follows.

Pitch: 5 mm  
Rating electrical power 1/4 W (CHIP : 1/10 W)

- All resistors are in ohms.
- : nonflammable resistor.
- : fusible resistor.
- $\Delta$  : internal component.
- : panel designation, and adjustment for repair.
- All variable and adjustable resistors have characteristic curve B, unless otherwise noted.
- $\perp$  : earth-ground.
- $\text{---}\text{---}$  : earth-chassis.
- The components identified by in this basic schematic diagram have been carefully factory-selected for each set in order to satisfy regulations regarding X-ray radiation. Should replacement be required, replace only with the value originally used.
- When replacing components identified by , make the necessary adjustments indicated. (See page 3-1)
- When replacing the part in below table, be sure to perform the related adjustment.

**Note: The components identified by shading and mark  $\Delta$  are critical for safety. Replace only with part number specified.**

**Note: Les composants identifiés par un tramé et une marque  $\Delta$  sont critiques pour la sécurité. Ne les remplacer que par une pièce portant le numéro spécifié.**

- All voltages are in V.
- Readings are taken with a 10 M $\Omega$  digital multimeter.
- Readings are taken with a color-bar signal input.
- Voltage variations may be noted due to normal production tolerances.
- \* : Can not be measured.
- Circled numbers are waveform references.
- : B + bus.
- : B - bus.

### Divided circuit diagram

One sheet of D board circuit diagram is divided into three sheets, each having the code D- $\text{\textcircled{a}}$  to D- $\text{\textcircled{c}}$ . For example, the destination  $\text{\textcircled{ab1}}$  on the code D- $\text{\textcircled{a}}$  sheet is connected to  $\text{\textcircled{ab1}}$  on the D- $\text{\textcircled{b}}$  sheet.

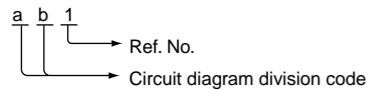

	Part Replaced (  )	
HV ADJ		RV901
	Part Replaced (  )	
HV Regulator Circuit Check	D Board	T901 (FBT), IC901, R924, R925, RV901 • Mounted D board
HV Protector Circuit Check	D Board	T901 (FBT), R917, R918, R923, R920, R919, R1004, C920, D911, D912 • Mounted D board
Beam Current Protector Circuit Check	D Board	R933, R932, R921, R1006, D915, D917, IC901, T901 (FBT) • Mounted D board

### Terminal name of semiconductors in silk screen printed circuit (※)

	Device	Printed symbol	Terminal name	Circuit
①	Transistor		Collector Base Emitter	
②	Transistor		Collector Base Emitter	
③	Diode		Cathode Anode	
④	Diode		Cathode Anode (NC)	
⑤	Diode		Cathode Anode (NC)	
⑥	Diode		Common Anode Cathode	
⑦	Diode		Common Anode Cathode	
⑧	Diode		Common Anode Anode	
⑨	Diode		Common Anode Anode	
⑩	Diode		Common Cathode Cathode	
⑪	Diode		Common Cathode Cathode	
⑫	Diode		Anode Anode Cathode Anode	
⑬	Transistor (FET)		Drain Source Gate	
⑭	Transistor (FET)		Drain Source Gate	
⑮	Transistor (FET)		Source Drain Gate	
⑯	Transistor		Emitter Collector Base	
—	Discrete semiconductor			

(Chip semiconductors that are not actually used are included.)

Ver.1.6

## A VIDEO AMP RGB OUT — A BOARD —

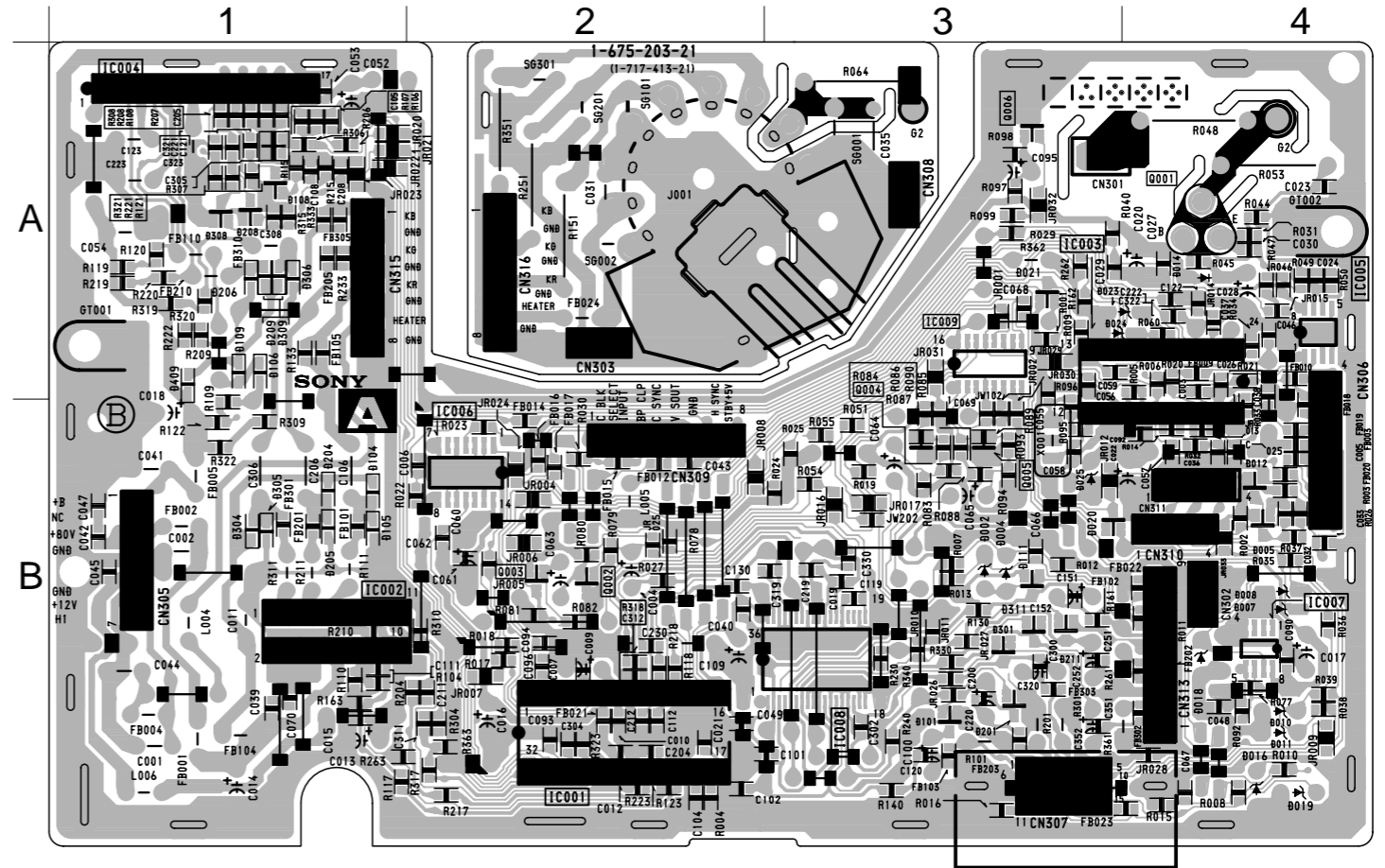

**NOTE:**  
The circuit indicated as left contains high voltage of over 600 Vp-p. Care must be paid to prevent an electric shock in inspection or repairing.

### • A BOARD SEMICONDUCTOR LOCATION

IC		DIODE		CRYSTAL	
IC001	B-2		*	D206	A-1 ③
IC002	B-1			D208	A-1 ③
IC003	A-4	D004	B-3	D209	A-1 ③
IC004	A-1	D005	B-4	D211	B-3 ⑥
IC005	A-4	D007	B-4	D301	B-3 ⑥
IC006	B-2	D008	B-4	D304	B-1 ③
		D014	A-4	D305	B-1 ③
		D023	A-3	D306	A-1 ③
		D024	A-3	D308	A-1 ⑥
		D025	B-3	D309	A-1 ⑦
		D104	B-1	D311	B-3 ③
		D105	B-1	D409	A-1 ③
		D106	A-1		
		D108	A-1		
		D109	A-1		
		D111	B-3		
		D204	B-1		
		D205	B-1		
				X001	B-3

※: Refer to Terminal name of semiconductors in silk screen printed circuit (see page 5-7)

• A BOARD WAVEFORMS

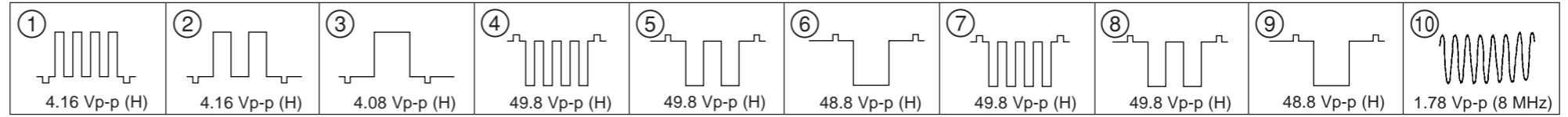

(1) Schematic Diagram of A Board

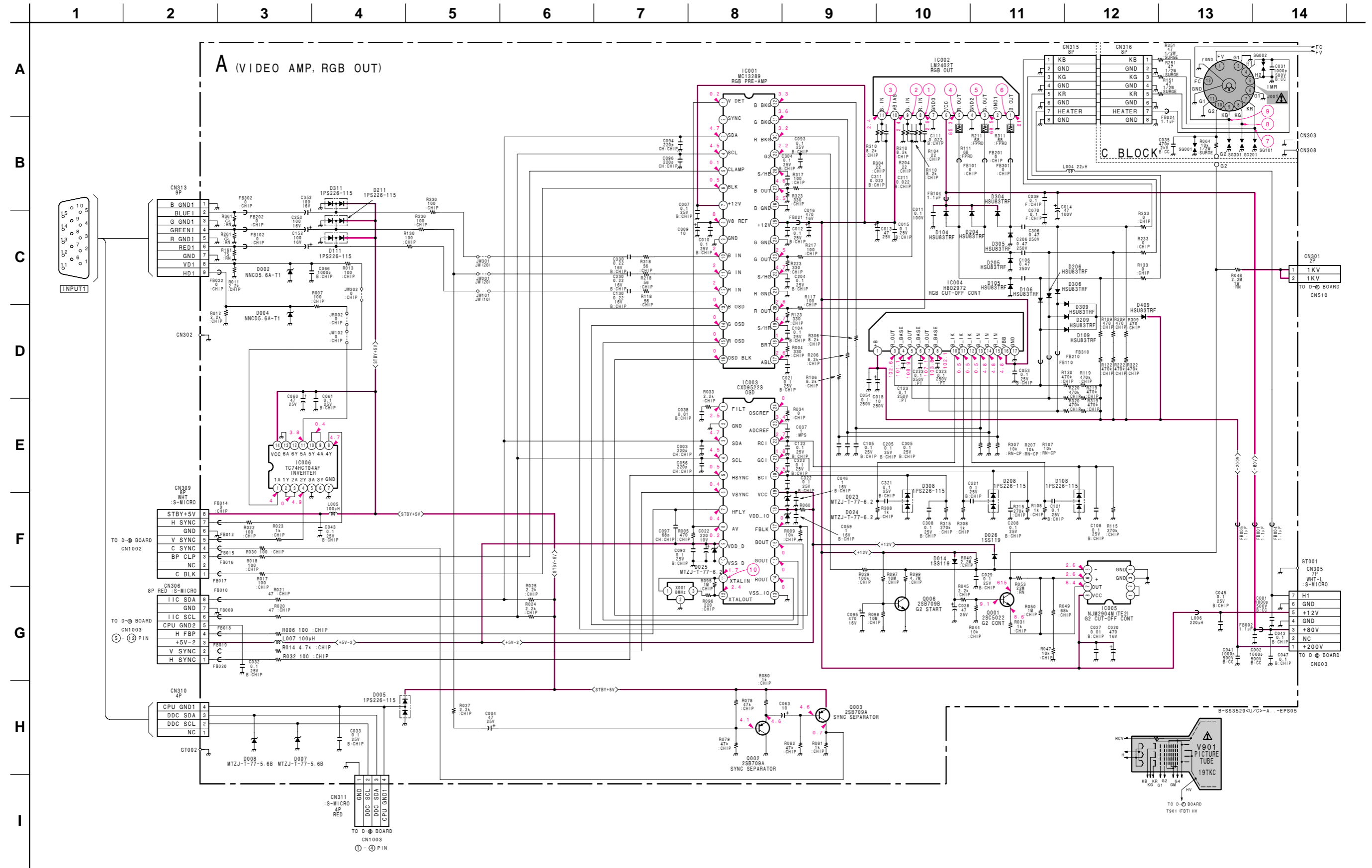

(2) Schematic Diagrams of D (a, b, c) Board

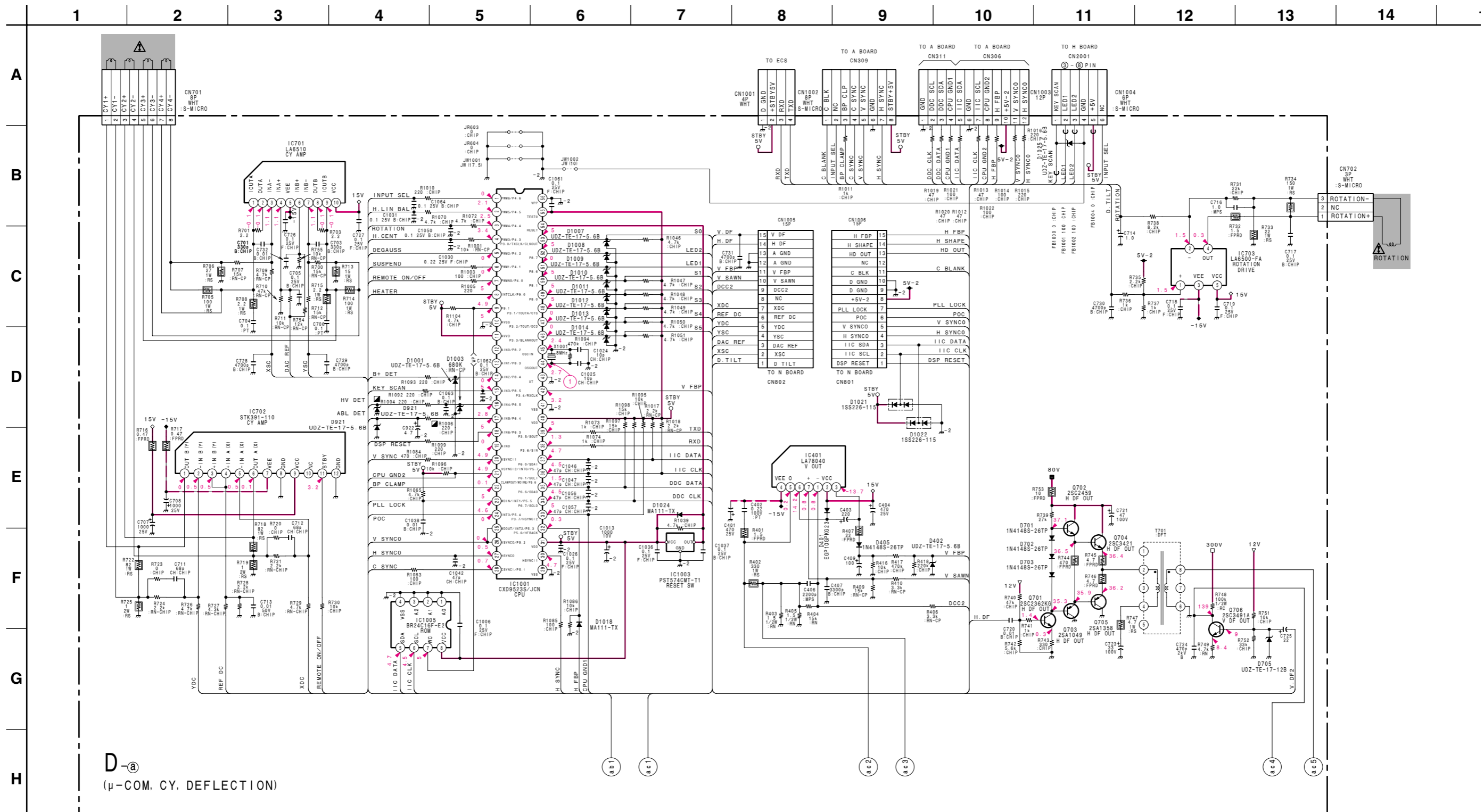

B-SS3529U/C2-D.-P1-EP805

• Divided circuit diagram  
 One sheet of D board circuit diagram is divided into three sheets, each having the code D-a) to D-c). For example, the destination ab1) on the code D-a) sheet is connected to ab1) on the D-b) sheet.

a b 1  
 → Ref. No.  
 → Circuit diagram division code

• D-a) BOARD WAVEFORM

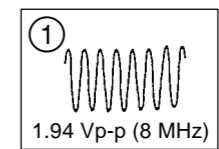





**D BOARD**

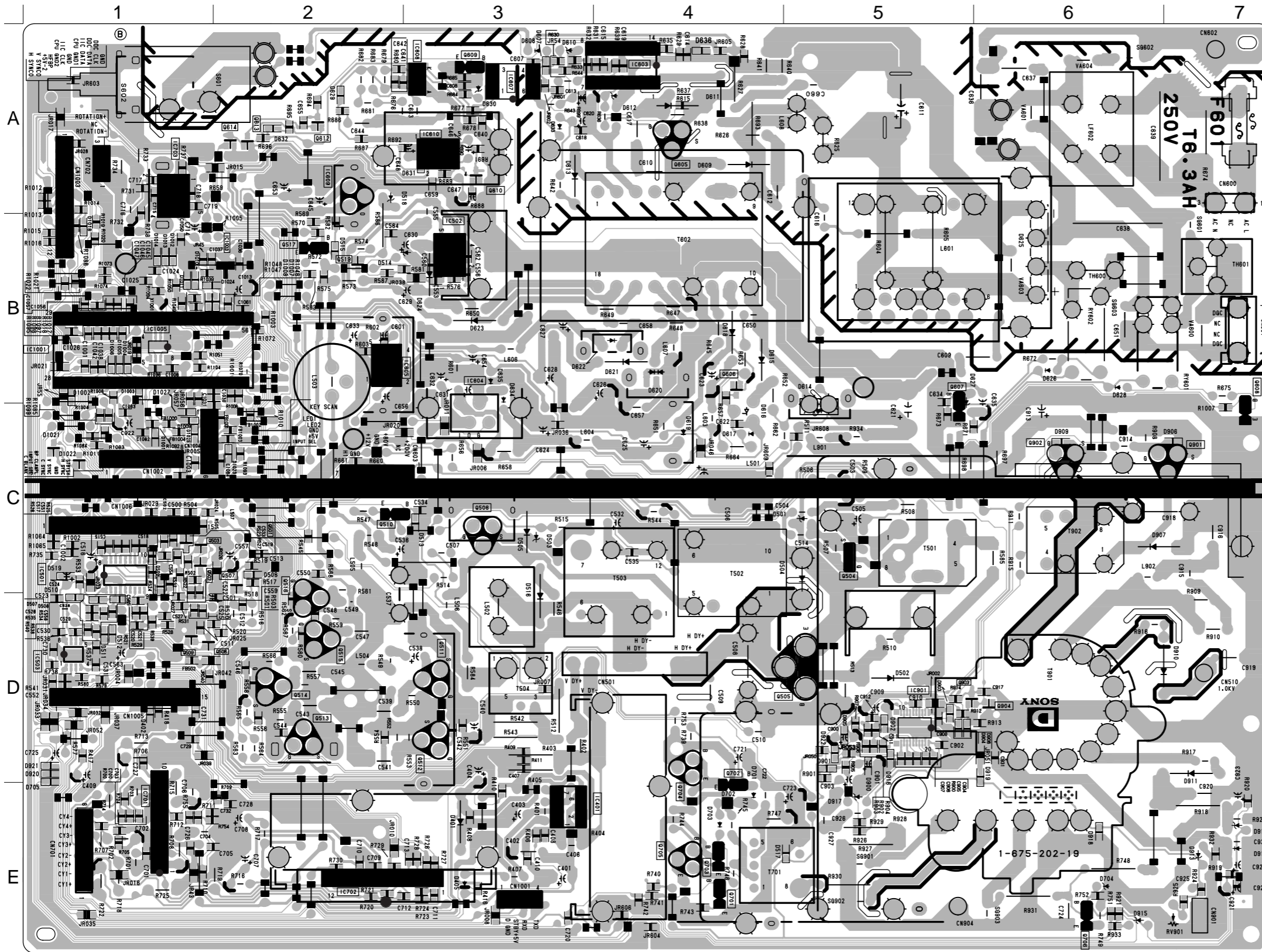

**NOTE:**  
The circuit indicated as left contains high voltage of over 600 Vp-p. Care must be paid to prevent an electric shock in inspection or repairing.

(3) Schematic Diagrams of N, H Boards

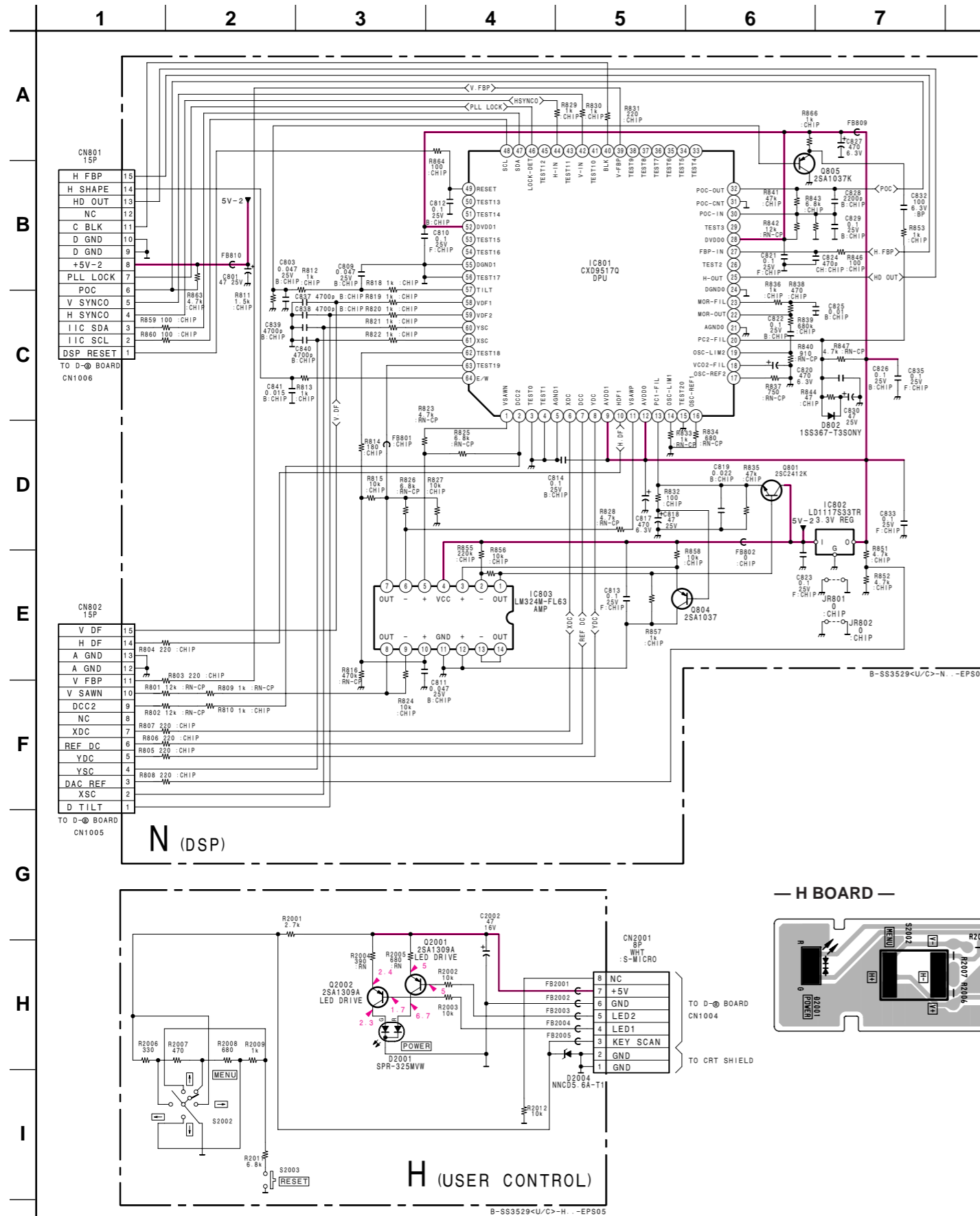

— N BOARD (Conductor Side) —

— N BOARD (Component Side) —

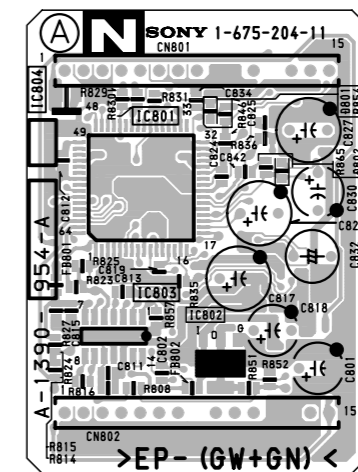
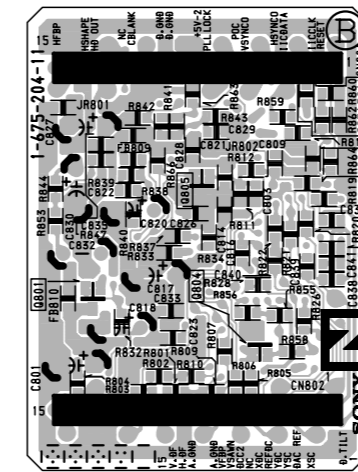

**N BOARD**  
Terminal name of semiconductors in silk screen printed circuit (\*):

Ref.	*
Q801, Q804, Q805	①
D802	③

\*: Refer to Terminal name of semiconductors in silk screen printed circuit (see page 5-7)

— H BOARD —

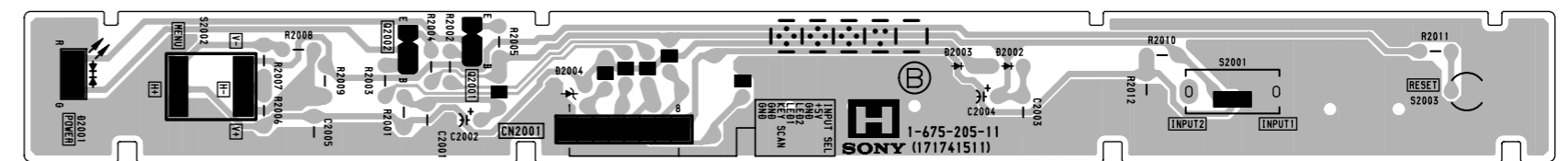



## 5-5. SEMICONDUCTORS

BA00AST-V5  
BA05T-V5  
H8D2972  
LA6500-FA

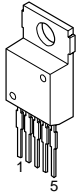

BA05T  
LD1117S33TR

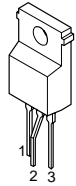

BA9758FS-E2  
BA9759F-E2

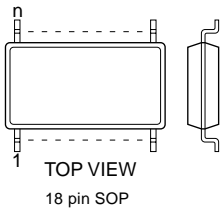

BR24C16F-E2  
NJM2904M  
NJM2904M(TE2)  
NJM4558M-TE2  
 $\mu$ PC4558G2

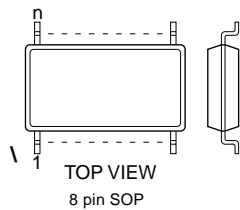

CXD9517Q

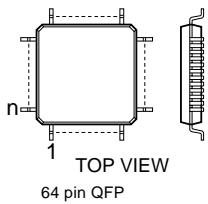

CXD9522S

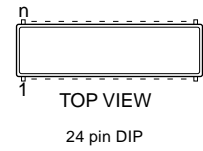

CXD9523S/JCN (Ver. 1.2)

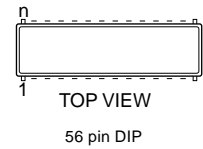

LA6510

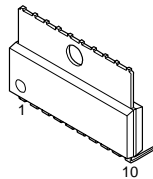

LM324M  
LA78040  
LM2402T

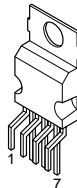

LM324M  
LM324M-FL63  
TC74HCT04AF  
TC74HCT04AF (EL)

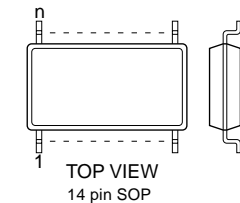

MC13289

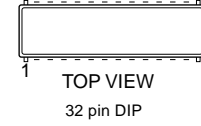

PQ12RD8S

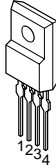

PST574CMT-T1

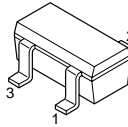

STK391-110

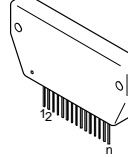

TEA1504/N2

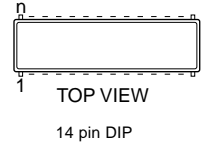

DTC143ESA  
DTC143ESA-TP  
PDTTC114-EK-115  
2SA1049-GR  
2SA1049TP-GR



FS5KM-16A  
FS5KM-18A-AY  
IRFI9634G-LF35  
2SK3265 (LB2SONY)

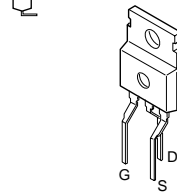

IRFU110  
IRFU110A

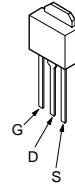

2SA1036K-Q  
2SA1036K-T-146-Q  
2SA1037AK-T146-R  
2SA1037AK-T146-QR  
2SA1037K-T-146-QR  
2SA1162-G  
2SB709A-QRS-TX  
2SC1623-L5L6  
2SC1623-T1-L5L6  
2SC2411K-CQ  
2SC2411K-T-146-CQ  
2SC2412K-T-146-QR

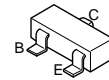

2SA1358-Y  
2SC3421-Y

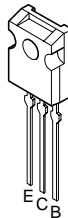

2SC2362K-G  
2SC2362KG-AA

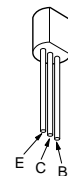

2SA1175-HFE  
2SA1309A-QRSTA  
2SC2459-GR-TPE4  
2SC2784  
2SC2785-HFE  
2SC3311A-QRSTA  
2SC3311A-RTA

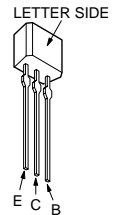

2SC3209LK  
2SC3209LK-TP

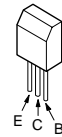

2SC3941A-Q (TA)

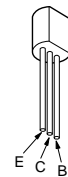

2SC5022-02

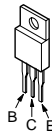

2SC5445 (LBSONY1)



2SK2098-01MR-F119

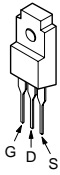

D2L40-TA  
ERB38-06V1  
HSS82  
MTZJ-T-77-18  
MTZJ-T-77-5.6B  
NNCD5.6A-T1  
RGP02-17EL-6433  
RGP02-17PKG23  
RGP10DG23  
UF4007G23  
1N4148S-26TP  
1SS367-T3SONY

EGP10DPKG23  
HZS182-TE  
HZS9.1NB2  
MTZJ-T-77-15B  
MTZJ-T-77-4.7B  
MTZJ-T-77-6.2  
MTZJ-4.7C  
MTZJ-6.2B  
RD10ES-T1B2  
RD10ESB2  
RD15ES-B2  
RD16ES-B3  
RD16ES-T1B2  
RD18ES-B2  
RD18ESB  
RD4.7ES-T1B2  
RD4.7ESB2  
RD5.1ES-B2  
RD5.1ES-T1B2  
RD5.6ESB2  
RD8.2ES-B2  
RD8.2ES-T1B2  
RD9.1ES-T1B2  
1SS119  
1SS119-25  
1SS119-25TD

1PS226-115

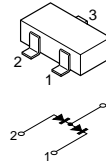

BT149G-412-OT359  
TL1431CZ-AP

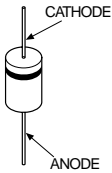
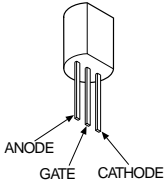

1SS376TE-17

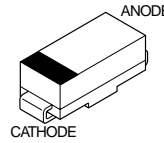

DTZ-TT11-15B  
DTZ-4.7C  
MA111-(K8).S0  
MA111-TX  
RD12SB2  
RD5.6S-B  
UDZ-TE-17-12B  
UDZ-TE-17-15B  
UDZ-TE-17-4.7B  
UDZ-TE-17-5.6B

D4L20U  
FMC-26UA  
FMN-G12S  
FMQ-G5FMS  
PG124S15  
YG911S2R

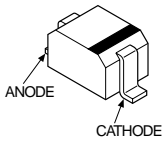
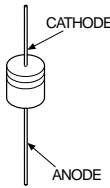
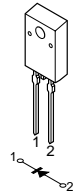

D4SB60L  
D4SB60L-F

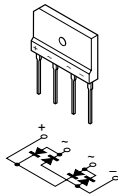

HSU83TRF

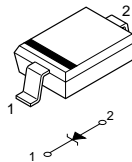

D10SC9M

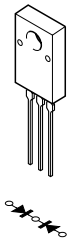

D3S4M  
EGP10D  
EGP10GPKG23  
ERA91-02  
ERA91-02TP1  
ERC81-004  
RH-1A

SPR325MVW

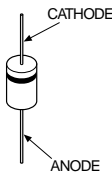
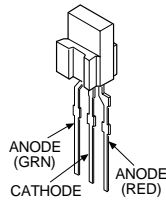

TLP621D4-Y-LF2T

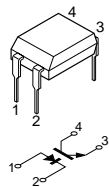

## SECTION 6 EXPLODED VIEWS

- Items with no part number and no description are not stocked because they are seldom required for routine service.
- The construction parts of an assembled part are indicated with a collation number in the remark column.

- Items marked " \* " are not stocked since they are seldom required for routine service. Some delay should be anticipated when ordering these items.

The components identified  $\triangle$  marked are critical for safety.  
Replace only with the part number specified.

Les composants identifiés par la marque  $\triangle$  sont critiques pour la sécurité.  
Ne les remplacer que par une pièce portant le numéro spécifié.

### 6-1. CHASSIS

- 7-685-881-09 +BVTT 4X8
- 7-685-872-09 +BVTT 3X8
- 7-685-646-79 +BVTP 3X8
- 7-685-663-71 +BVTP 4X16

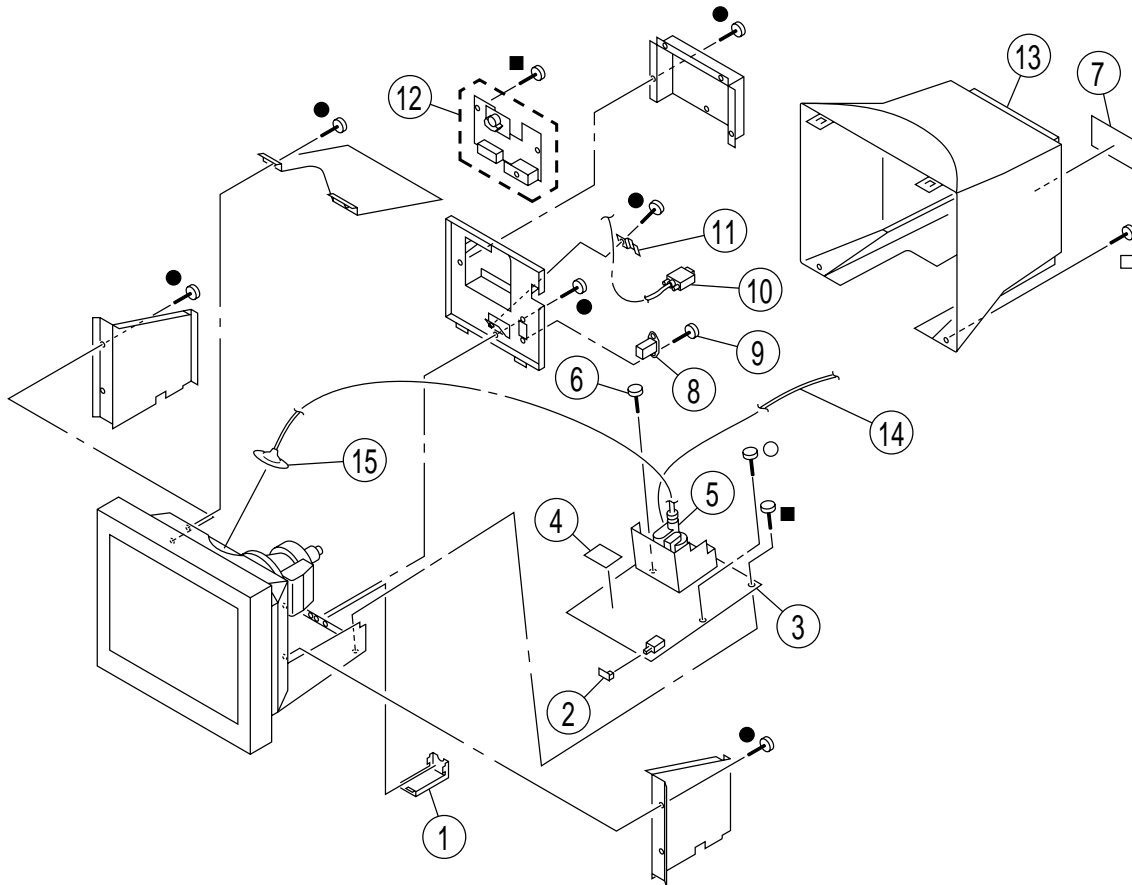

REF.NO.	PART NO.	DESCRIPTION	REMARK	REF.NO.	PART NO.	DESCRIPTION	REMARK
1	* 4-072-434-01	COVER, CABLE [E400]		#1 10	* 1-790-283-21	CABLE ASSY (15P DSUB CONNECTOR) [E400E, E400P]	
1	4-072-438-01	COVER, CABLE [E400E, E400P]		11	* 4-045-131-01	STOPPER, CABLE [E400]	
2	* 4-394-972-21	CAP, POWER		11	* 4-045-131-11	STOPPER, CABLE [E400E, E400P]	
#1 3	* A-1348-045-A	D BOARD, COMPLETE [E400]	5	12	* A-1299-002-A	A BOARD, COMPLETE [E400]	
#1 3	* A-1348-869-A	D BOARD, COMPLETE [E400E]	5	#1 12	* A-1299-211-A	A BOARD, COMPLETE [E400E]	
#2 3	* A-1642-279-A	D BOARD, COMPLETE [E400P]	5	#1 12	* A-1632-915-A	A BOARD, COMPLETE [E400P made in UK]	
4	* A-1390-957-A	N BOARD, COMPLETE [E400]		#2 12	* A-1632-926-A	A BOARD, COMPLETE [E400P made in Thailand]	
4	* A-1390-978-A	N BOARD, COMPLETE [E400E]		13	* 4-072-433-11	CABINET [E400]	
#2 4	* A-1652-076-A	N BOARD, COMPLETE [E400P]		#1 13	4-072-437-11	CABINET [E400E]	
5	$\triangle$ X-4560-174-1	TRANSFORMER ASSY, FLYBACK (NX4700/J1E4)		#2 13	4-072-437-31	CABINET [E400P]	
6	4-062-115-01	SCREW +P 3.5X20 TYPE2		#1 14	1-900-805-51	WIRE ASSY, FOCUS LEAD	
7	* 4-073-936-01	LABEL, INFORMATION [only E400]		#1 15	1-251-642-41	CAP ASSY, HIGH-VOLTAGE	
8	$\triangle$ 1-251-382-31	INLET, AC 3P (WITH NOISE FILTER)					
9	4-052-345-01	SCREW, (3X8) (+K), TAPPING					
10	1-783-982-11	CABLE ASSY (15P DSUB CONNECTOR) [E400]					

# CPD-E400/E400E/E400P

The components identified  $\triangle$  marked are critical for safety.  
Replace only with the part number specified.

Les composants identifiés par la marque  $\triangle$  sont critiques pour la sécurité.  
Ne les remplacer que par une pièce portant le numéro spécifié.

## 6-2. PICTURE TUBE

- 7-685-881-09 +BVTT 4X8
- 7-685-663-71 +BVTP 4X16
- ▲ 7-685-882-09 +BVTT 4X10

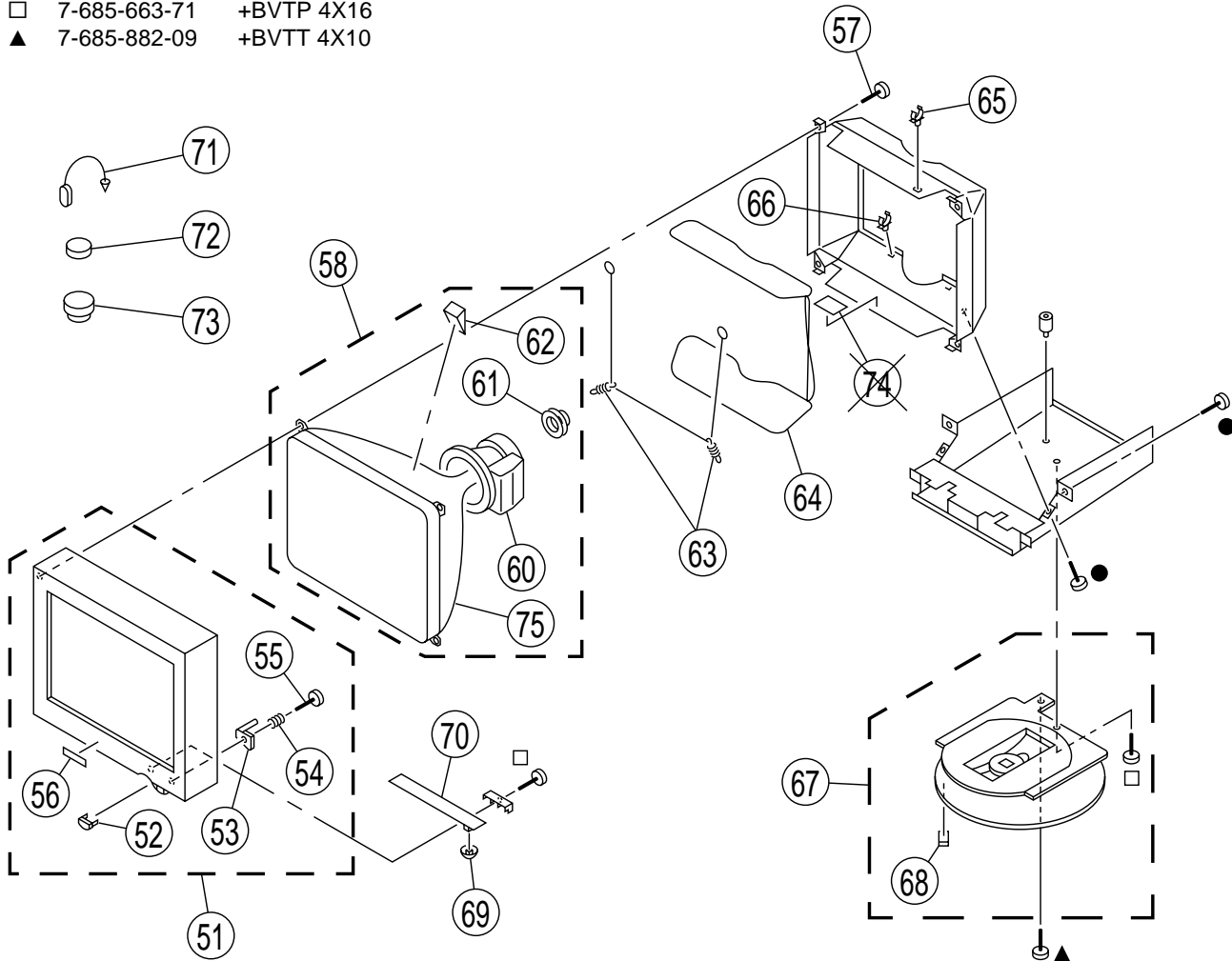

REF.NO.	PART NO.	DESCRIPTION	REMARK	REF.NO.	PART NO.	DESCRIPTION	REMARK
51	X-4037-401-1	BEZEL ASSY [E400]	52-56	63	* 4-047-316-01	SPRING, TENSION [E400E, E400P]	
51	X-4037-315-1	BEZEL ASSY [E400E, E400P]	52-56	64	$\triangle$ 1-419-285-11	COIL, DEGAUSSING	
52	4-071-152-11	BUTTON, POWER [E400]		#3 65	<del>4-395-824-01</del>	<del>HOLDER, DEGAUSSING COIL [E400]</del>	
52	4-204-957-01	BUTTON, POWER [E400E, E400P]		65	4-071-175-01	HOLDER, DEGAUSSING COIL	[E400E, E400P]
53	* 4-072-435-01	BAR, EXTENSION [E400]		66	4-041-021-11	HOLDER, DEGAUSE COIL [E400]	
53	4-072-439-01	BAR, EXTENSION [E400E, E400P]		66	4-041-021-02	HOLDER, DEGAUSE COIL [E400E, E400P]	
54	4-070-001-11	SPRING, COMPRESSION [E400]		67	X-4036-988-1	ASSY, STAND	68
54	4-205-260-01	SPRING, COMPRESSION [E400E, E400P]		68	* 4-061-996-11	CUSHION	
55	4-046-797-01	SCREW (3X12), (+) BVTP		69	4-071-155-01	BUTTON, MENU [E400]	
#3 56	<del>4-044-932-31</del>	<del>EMBLEM (NO.8), SONY [E400]</del>		69	4-204-970-01	BUTTON, MENU [E400E, E400P]	
56	4-044-932-11	EMBLEM (NO.8), SONY [E400E, E400P]		#1 70	* A-1372-801-A	H BOARD, COMPLETE [E400]	
57	4-365-808-01	SCREW (5), TAPPING [E400]		70	* A-1372-744-A	H BOARD, COMPLETE [E400E]	
57	4-203-648-01	SCREW (5), TAPPING [E400E, E400P]		#2 70	* A-1646-234-A	H BOARD, COMPLETE [E400P]	
58	$\triangle$ 8-736-407-61	ITC ASSY (19TKC-R1)	60-62, 75	71	4-308-870-00	CLIP, LEAD WIRE	
60	$\triangle$ 8-451-284-11	DEFLECTION YOKE Y19TKK-V		72	1-452-032-00	MAGNET, DISC	
61	$\triangle$ 1-452-912-61	NECK ASSEMBLY (NA-2914)		73	1-452-094-00	MAGNET, ROTATABLE DISC; 15mm $\phi$	
62	4-040-897-01	SPACER, DEFLECTION YOKE [E400]		#3 74	<del>4-070-217-01</del>	<del>CUSHION [only E400E]</del>	
62	2-162-100-21	SPACER, DEFLECTION YOKE	[E400E, E400P]	#1 75	$\triangle$ 8-736-407-05	PICTURE TUBE 19TKC (SDP)	
63	* 4-061-573-01	SPRING, TENSION [E400]					

6-3. PACKING MATERIALS

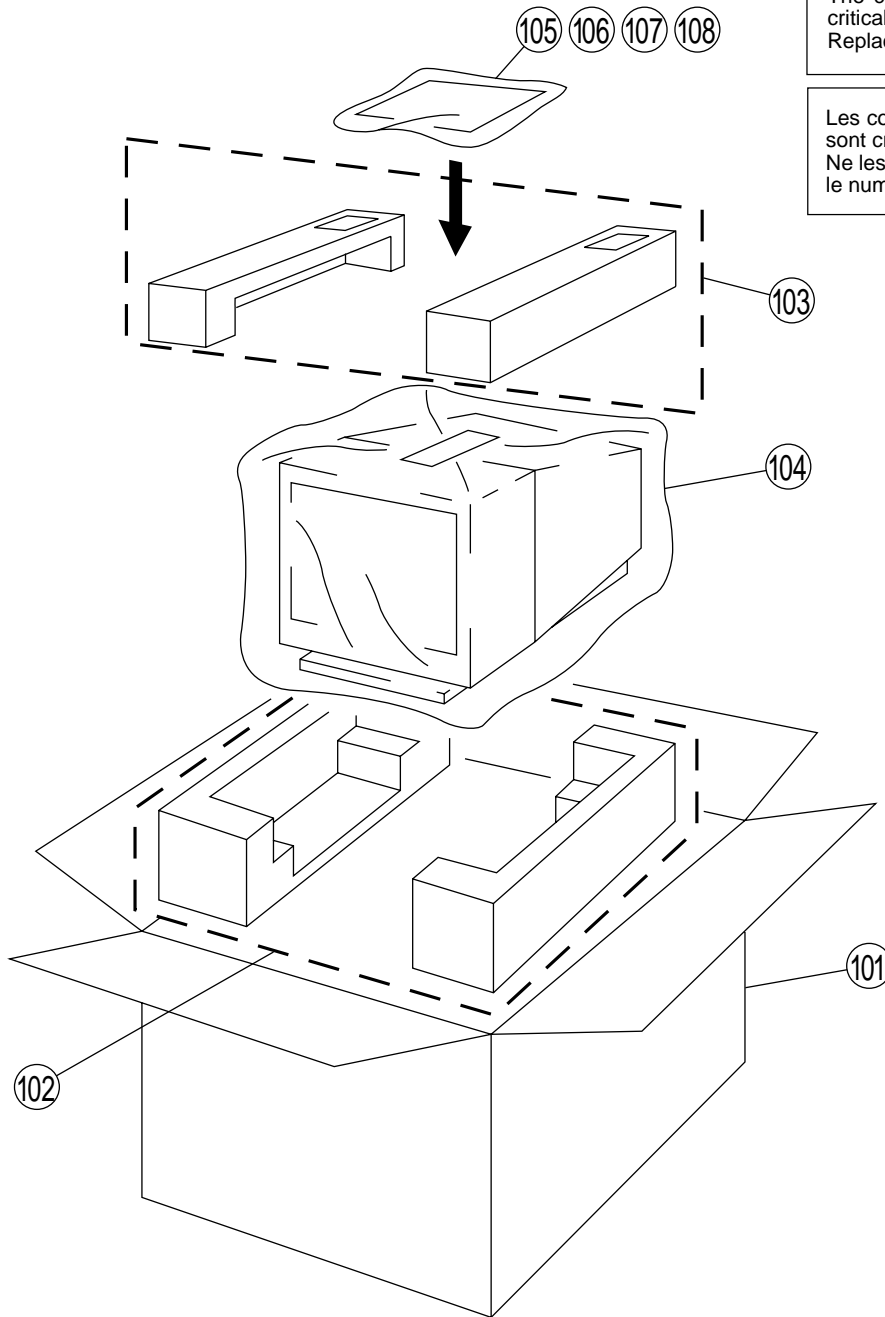

The components identified  $\triangle$  marked are critical for safety. Replace only with the part number specified.

Les composants identifiés par la marque  $\triangle$  sont critiques pour la sécurité. Ne les remplacer que par une pièce portant le numéro spécifié.

REF.NO.	PART NO.	DESCRIPTION	REMARK	REF.NO.	PART NO.	DESCRIPTION	REMARK
#1	101	* 4-078-894-01	INDIVIDUAL CARTON [E400]	#1	105	1-772-337-31	DISK, INFORMATION [E400E]
	101	4-072-908-01	INDIVIDUAL CARTON [E400E]		106	$\triangle$ 1-790-662-11	CORD SET, POWER [E400]
#2	101	* 4-078-602-01	INDIVIDUAL CARTON [E400P]		106	$\triangle$ 1-765-719-31	CORD SET, POWER [E400E, E400P]
#1	102	* 4-077-229-01	CUSHION (LOWER) (ASSY) [E400]		107	1-785-512-21	CONNECTOR, DSUB (15P CHANGER) [E400]
	102	* 4-072-903-01	CUSHION (LOWER) (ASSY) [E400E]		107	1-785-512-31	CONNECTOR, DSUB (15P CHANGER) [E400E, E400P]
#2	102	* 4-205-926-01	CUSHION (LOWER) (ASSY) [E400P]		108	4-074-104-11	MANUAL, INSTRUCTION [E400]
#1	103	* 4-077-230-01	CUSHION (UPPER) (ASSY) [E400]		108	4-075-351-11	MANUAL, INSTRUCTION [E400E]
	103	* 4-072-902-01	CUSHION (UPPER) (ASSY) [E400E]	#2	108	4-078-482-11	MANUAL, INSTRUCTION (PDF DATA) [E400P]
#2	103	* 4-205-921-01	CUSHION (UPPER) (ASSY) [E400P]				
	104	4-041-927-11	BAG, POLYETHYLENE				
#1	105	1-772-337-21	DISK, INFORMATION [E400]				

SECTION 7  
ELECTRICAL PARTS LIST



NOTE:

The components identified  $\Delta$  marked are critical for safety. Replace only with the part number specified.

Les composants identifiés par la marque  $\Delta$  sont critiques pour la sécurité. Ne les remplacer que par une pièce portant le numéro spécifié.

When indicating parts by reference number, please include the board name.

The components identified by  $\boxtimes$  in this manual have been carefully factory-selected for each set in order to satisfy regulations regarding X-ray radiation. Should replacement be required, replace only with the value originally used.

• All variable and adjustable resistors have characteristic curve B, unless otherwise noted.

• Items marked " \* " are not stocked since they are seldom required for routine service. Some delay should be anticipated when ordering these items.

RESISTORS

• All resistors are in ohms  
• F : nonflammable

REF.NO.	PART NO.	DESCRIPTION	REMARK	REF.NO.	PART NO.	DESCRIPTION	REMARK
		A BOARD, COMPLETE *****		C056	1-163-259-91	CERAMIC CHIP 220pF	5% 50V
		4-382-854-01 SCREW (M3X8), P, SW (+) (IC002)		C059	1-164-346-11	CERAMIC CHIP 1 $\mu$ F	16V
		<CAPACITOR>		C060	1-104-664-11	ELECT 47 $\mu$ F	20% 25V
C001	1-162-318-11	CERAMIC 0.001 $\mu$ F	10% 500V	C061	1-164-004-11	CERAMIC CHIP 0.1 $\mu$ F	10% 25V
C002	1-162-318-11	CERAMIC 0.001 $\mu$ F	10% 500V	C063	1-126-964-11	ELECT 10 $\mu$ F	20% 50V
C003	1-163-259-91	CERAMIC CHIP 220pF	5% 50V	C066	1-163-009-11	CERAMIC CHIP 0.001 $\mu$ F	10% 50V
C004	1-104-664-91	ELECT 47 $\mu$ F	20% 25V	C070	1-165-319-11	CERAMIC CHIP 0.1 $\mu$ F	50V
C007	1-164-004-11	CERAMIC CHIP 0.1 $\mu$ F	10% 25V	C092	1-164-004-11	CERAMIC CHIP 0.1 $\mu$ F	10% 25V
C009	1-126-964-11	ELECT 10 $\mu$ F	20% 50V	C093	1-164-004-11	CERAMIC CHIP 0.1 $\mu$ F	10% 25V
C010	1-164-004-11	CERAMIC CHIP 0.1 $\mu$ F	10% 25V	C094	1-163-259-91	CERAMIC CHIP 220pF	5% 50V
C011	1-106-220-00	MYLAR 0.1 $\mu$ F	10% 100V	C095	1-126-935-11	ELECT 470 $\mu$ F	20% 16V
C012	1-164-004-11	CERAMIC CHIP 0.1 $\mu$ F	10% 25V	C096	1-163-259-91	CERAMIC CHIP 220pF	5% 50V
C013	1-107-888-11	ELECT 47 $\mu$ F	20% 25V	C097	1-163-113-00	CERAMIC CHIP 68pF	5% 50V
C014	1-107-932-11	ELECT 47 $\mu$ F	20% 100V	C104	1-164-004-11	CERAMIC CHIP 0.1 $\mu$ F	10% 25V
C015	1-164-004-11	CERAMIC CHIP 0.1 $\mu$ F	10% 25V	C105	1-164-004-11	CERAMIC CHIP 0.1 $\mu$ F	10% 25V
C016	1-126-935-11	ELECT 470 $\mu$ F	20% 16V	C106	1-117-450-11	MYLAR 0.47 $\mu$ F	10% 250V
C018	1-107-652-11	ELECT 10 $\mu$ F	20% 250V	C108	1-164-004-11	CERAMIC CHIP 0.1 $\mu$ F	10% 25V
C020	1-126-935-11	ELECT 470 $\mu$ F	20% 16V	C111	1-163-037-11	CERAMIC CHIP 0.022 $\mu$ F	10% 50V
C021	1-164-004-11	CERAMIC CHIP 0.1 $\mu$ F	10% 25V	C121	1-164-004-11	CERAMIC CHIP 0.1 $\mu$ F	10% 25V
C022	1-126-934-11	ELECT 220 $\mu$ F	20% 10V	C122	1-164-004-11	CERAMIC CHIP 0.1 $\mu$ F	10% 25V
C027	1-163-021-91	CERAMIC CHIP 0.01 $\mu$ F	10% 50V	C123	1-104-341-11	MYLAR 0.1 $\mu$ F	10% 250V
C028	1-104-664-11	ELECT 47 $\mu$ F	20% 25V	C130	1-164-489-11	CERAMIC CHIP 0.22 $\mu$ F	10% 16V
C029	1-164-004-11	CERAMIC CHIP 0.1 $\mu$ F	10% 25V	C152	1-126-933-11	ELECT 100 $\mu$ F	20% 16V
C031	1-162-318-11	CERAMIC 0.001 $\mu$ F	10% 500V	C204	1-164-004-11	CERAMIC CHIP 0.1 $\mu$ F	10% 25V
C032	1-164-004-11	CERAMIC CHIP 0.1 $\mu$ F	10% 25V	C205	1-164-004-11	CERAMIC CHIP 0.1 $\mu$ F	10% 25V
C033	1-164-004-11	CERAMIC CHIP 0.1 $\mu$ F	10% 25V	C206	1-117-450-11	MYLAR 0.47 $\mu$ F	10% 250V
C035	1-162-134-11	CERAMIC 470pF	10% 2KV	C208	1-164-004-11	CERAMIC CHIP 0.1 $\mu$ F	10% 25V
C037	1-136-177-00	MYLAR 1 $\mu$ F	5% 50V	C211	1-163-037-11	CERAMIC CHIP 0.022 $\mu$ F	10% 50V
C038	1-163-021-91	CERAMIC CHIP 0.001 $\mu$ F	10% 50V	C221	1-164-004-11	CERAMIC CHIP 0.1 $\mu$ F	10% 25V
C039	1-165-319-11	CERAMIC CHIP 0.1 $\mu$ F	50V	C222	1-164-004-11	CERAMIC CHIP 0.1 $\mu$ F	10% 25V
C041	1-162-318-11	CERAMIC 0.001 $\mu$ F	10% 500V	C223	1-104-341-11	MYLAR 0.1 $\mu$ F	10% 250V
C042	1-165-319-11	CERAMIC CHIP 0.1 $\mu$ F	50V	C230	1-164-489-11	CERAMIC CHIP 0.22 $\mu$ F	10% 16V
C043	1-164-004-11	CERAMIC CHIP 0.1 $\mu$ F	10% 25V	C252	1-126-933-11	ELECT 100 $\mu$ F	20% 16V
C045	1-164-004-11	CERAMIC CHIP 0.1 $\mu$ F	10% 25V	C304	1-164-004-11	CERAMIC CHIP 0.1 $\mu$ F	10% 25V
C046	1-164-346-11	CERAMIC CHIP 1 $\mu$ F	10% 16V	C305	1-164-004-11	CERAMIC CHIP 0.1 $\mu$ F	10% 25V
C047	1-165-319-11	CERAMIC CHIP 0.1 $\mu$ F	50V	C306	1-117-450-11	MYLAR 0.47 $\mu$ F	10% 250V
C053	1-164-004-11	CERAMIC CHIP 0.1 $\mu$ F	10% 25V	C308	1-164-004-11	CERAMIC CHIP 0.1 $\mu$ F	10% 25V
C054	1-104-341-11	MYLAR 0.1 $\mu$ F	10% 250V	C311	1-163-037-11	CERAMIC CHIP 0.022 $\mu$ F	10% 50V
				C321	1-164-004-11	CERAMIC CHIP 0.1 $\mu$ F	10% 25V
				C322	1-164-004-11	CERAMIC CHIP 0.1 $\mu$ F	10% 25V
				C323	1-104-341-11	MYLAR 0.1 $\mu$ F	10% 250V
				C330	1-164-489-11	CERAMIC CHIP 0.22 $\mu$ F	10% 16V
				C352	1-126-933-11	ELECT 100 $\mu$ F	20% 16V

# CPD-E400/E400E/E400P



Les composants identifiés par la marque  $\Delta$  sont critiques pour la sécurité.  
Ne les remplacer que par une pièce portant le numéro spécifié.

The components identified  $\Delta$  marked are critical for safety.  
Replace only with the part number specified.

REF.NO.	PART NO.	DESCRIPTION	REMARK	REF.NO.	PART NO.	DESCRIPTION	REMARK
		<CONNECTOR>		FB016	1-414-231-22	INDUCTOR CHIP	
CN301	1-764-101-11	PIN, CONNECTOR (PC BOARD)	2P	FB017	1-414-231-22	INDUCTOR CHIP	
CN302	1-695-915-11	TAB (CONTACT)		FB018	1-414-231-22	INDUCTOR CHIP	
CN303	1-695-915-11	TAB (CONTACT)		FB019	1-414-231-22	INDUCTOR CHIP	
CN305*	1-564-522-11	PLUG, CONNECTOR	7P	FB020	1-414-231-22	INDUCTOR CHIP	
CN306*	1-564-511-11	PLUG, CONNECTOR	8P	FB021	1-414-231-22	INDUCTOR CHIP	
CN308	1-695-915-11	TAB (CONTACT)		FB022	1-216-295-91	SHORT	0
CN309*	1-564-511-11	PLUG, CONNECTOR	8P	FB024	1-412-911-11	FERRITE	1.1 $\mu$ H
CN310*	1-779-944-21	PIN, CONNECTOR (PC BOARD)	4P	FB101	1-216-295-91	SHORT	0
CN311*	1-564-507-11	PLUG, CONNECTOR	4P	FB102	1-216-295-91	SHORT	0
CN313*	1-785-705-11	PIN, CONNECTOR (PC BOARD)	9P	FB104	1-412-911-11	FERRITE	1.1 $\mu$ H
		<DIODE>		FB110	1-412-911-11	FERRITE	1.1 $\mu$ H
D002	8-719-109-89	ZENER DIODE RD5.6ESB2		FB201	1-216-295-91	SHORT	0
D004	8-719-109-89	ZENER DIODE RD5.6ESB2		FB202	1-216-295-91	SHORT	0
D005	8-719-062-51	DIODE 1PS226-115		FB210	1-412-911-11	FERRITE	1.1 $\mu$ H
D007	8-719-109-89	ZENER DIODE RD5.6ESB2		FB301	1-216-295-91	SHORT	0
D008	8-719-109-89	ZENER DIODE RD5.6ESB2		FB302	1-216-295-91	SHORT	0
D014	8-719-911-19	DIODE 1SS119-25		FB310	1-412-911-11	FERRITE	1.1 $\mu$ H
D023	8-719-921-54	DIODE MTZJ-6.2B				<TERMINAL>	
D024	8-719-921-54	DIODE MTZJ-6.2B		GT001*	1-537-738-21	TERMINAL, EARTH	
D025	8-719-921-54	DIODE MTZJ-6.2B		GT002*	1-537-738-21	TERMINAL, EARTH	
D026	8-719-911-19	DIODE 1SS119-25				<IC>	
D104	8-719-052-12	DIODE 1SS376TE-17		IC001	8-759-599-70	IC MC13289	
D105	8-719-052-12	DIODE 1SS376TE-17		IC002	8-759-591-40	IC LM2402T	
D106	8-719-052-12	DIODE 1SS376TE-17		IC003	8-759-639-50	IC CXD9522S	
D108	8-719-062-51	DIODE 1PS226-115		IC004	8-749-015-92	IC H8D2972	
D109	8-719-052-12	DIODE 1SS376TE-17		IC005	8-759-701-01	IC NJM2904M	
D111	8-719-062-51	DIODE 1PS226-115		IC006	8-759-233-66	IC TC74HCT04AF	
D204	8-719-052-12	DIODE 1SS376TE-17				<JACK>	
D205	8-719-052-12	DIODE 1SS376TE-17		J001 $\Delta$	1-451-499-11	SOCKET, PICTURE TUBE	
D206	8-719-052-12	DIODE 1SS376TE-17				<CHIP CONDUCTOR>	
D208	8-719-062-51	DIODE 1PS226-115		JR002	1-216-295-91	SHORT	0
D209	8-719-052-12	DIODE 1SS376TE-17		JR004	1-216-296-91	SHORT	0
D211	8-719-062-51	DIODE 1PS226-115		JR005	1-216-295-91	SHORT	0
D304	8-719-052-12	DIODE 1SS376TE-17		JR006	1-216-296-91	SHORT	0
D305	8-719-052-12	DIODE 1SS376TE-17		JR007	1-216-296-91	SHORT	0
D306	8-719-052-12	DIODE 1SS376TE-17		JR008	1-216-296-91	SHORT	0
D308	8-719-062-51	DIODE 1PS226-115		JR010	1-216-295-91	SHORT	0
D309	8-719-052-12	DIODE 1SS376TE-17		JR011	1-216-295-91	SHORT	0
D311	8-719-062-51	DIODE 1PS226-115		JR012	1-216-296-91	SHORT	0
D409	8-719-052-12	DIODE 1SS376TE-17		JR013	1-216-295-91	SHORT	0
		<FERRITE BEAD>		JR014	1-216-295-91	SHORT	0
FB001	1-412-911-11	FERRITE	1.1 $\mu$ H	JR015	1-216-295-91	SHORT	0
FB002	1-412-911-11	FERRITE	1.1 $\mu$ H	JR016	1-216-296-91	SHORT	0
FB004	1-412-911-11	FERRITE	1.1 $\mu$ H	JR017	1-216-296-91	SHORT	0
FB005	1-412-911-11	FERRITE	1.1 $\mu$ H	JR020	1-216-296-91	SHORT	0
FB009	1-414-231-22	INDUCTOR CHIP		JR021	1-216-296-91	SHORT	0
FB010	1-414-231-22	INDUCTOR CHIP					
FB012	1-414-231-22	INDUCTOR CHIP					
FB014	1-216-295-91	SHORT	0				
FB015	1-414-231-22	INDUCTOR CHIP					



REF.NO.	PART NO.	DESCRIPTION	REMARK	REF.NO.	PART NO.	DESCRIPTION	REMARK
JR022	1-216-296-91	SHORT	0	R044	1-216-073-00	RES,CHIP 10K	5% 1/10W
JR023	1-216-296-91	SHORT	0	R045	1-216-057-00	RES,CHIP 2.2K	5% 1/10W
JR024	1-216-296-91	SHORT	0	R047	1-216-073-00	RES,CHIP 10K	5% 1/10W
JR025	1-216-295-91	SHORT	0	R048	1-219-398-51	METAL 2.2M	5% 1W
JR026	1-216-295-91	SHORT	0	R049	1-216-093-91	RES,CHIP 68K	5% 1/10W
JR027	1-216-295-91	SHORT	0	R050	1-216-121-91	RES,CHIP 1M	5% 1/10W
JR028	1-216-295-91	SHORT	0	R053	1-219-621-91	METAL 22M	10% 1/4W
JR029	1-216-296-91	SHORT	0	R060	1-414-231-22	INDUCTOR CHIP	
JR030	1-216-295-91	SHORT	0	R064	1-219-749-91	CARBON 10K	5% 1/2W
JR031	1-216-296-91	SHORT	0	R078	1-216-089-91	RES,CHIP 47K	5% 1/10W
JR032	1-216-295-91	SHORT	0	R079	1-216-089-91	RES,CHIP 47K	5% 1/10W
JR033	1-216-296-91	SHORT	0	R080	1-216-049-91	RES,CHIP 1K	5% 1/10W
JR034	1-216-296-91	SHORT	0	R081	1-216-049-91	RES,CHIP 1K	5% 1/10W
JW120	1-216-295-91	SHORT	0	R082	1-216-089-91	RES,CHIP 47K	5% 1/10W
JW202	1-216-295-91	SHORT	0	R095	1-216-121-91	RES,CHIP 1M	5% 1/10W
<COIL>				R096	1-216-033-00	RES,CHIP 220	5% 1/10W
L004	1-412-529-11	INDUCTOR 22μH		R097	1-218-179-11	RES,CHIP 10M	5% 1/10W
L005	1-412-537-31	INDUCTOR 100μH		R098	1-218-179-11	RES,CHIP 10M	5% 1/10W
L006	1-412-541-41	INDUCTOR 220μH		R099	1-208-291-11	RES,CHIP 4.7M	5% 1/10W
L007	1-408-615-31	INDUCTOR 100μH		R104	1-216-009-91	RES,CHIP 22	5% 1/10W
<TRANSISTOR>				R106	1-216-071-00	RES,CHIP 8.2K	5% 1/10W
Q001	8-729-032-61	TRANSISTOR 2SC5022-02		R107	1-216-675-91	METAL CHIP 10K	0.5% 1/10W
Q002	8-729-216-22	TRANSISTOR 2SA1162-G		R108	1-216-049-91	RES,CHIP 1K	5% 1/10W
Q003	8-729-216-22	TRANSISTOR 2SA1162-G		R109	1-216-041-00	RES,CHIP 470	5% 1/10W
Q006	8-729-216-22	TRANSISTOR 2SA1162-G		R110	1-216-071-00	RES,CHIP 8.2K	5% 1/10W
<RESISTOR>				R111	1-249-403-11	CARBON 68	5% 1/4W F
R004	1-216-037-00	RES,CHIP 330	5% 1/10W	R115	1-216-107-00	RES,CHIP 270K	5% 1/10W
R005	1-216-041-00	RES,CHIP 470	5% 1/10W	R117	1-216-025-91	RES,CHIP 100	5% 1/10W
R006	1-216-025-91	RES,CHIP 100	5% 1/10W	R118	1-216-019-00	RES,CHIP 56	5% 1/10W
R007	1-216-025-91	RES,CHIP 100	5% 1/10W	R119	1-216-113-00	RES,CHIP 470K	5% 1/10W
R009	1-216-073-00	RES,CHIP 10K	5% 1/10W	R120	1-216-113-00	RES,CHIP 470K	5% 1/10W
R011	1-216-057-00	RES,CHIP 2.2K	5% 1/10W	R122	1-216-113-00	RES,CHIP 470K	5% 1/10W
R012	1-216-057-00	RES,CHIP 2.2K	5% 1/10W	R123	1-216-037-00	RES,CHIP 330	5% 1/10W
R013	1-216-025-91	RES,CHIP 100	5% 1/10W	R130	1-216-025-91	RES,CHIP 100	5% 1/10W
R014	1-216-065-91	RES,CHIP 4.7K	5% 1/10W	R133	1-216-295-91	SHORT 0	
R017	1-216-025-91	RES,CHIP 100	5% 1/10W	R151	1-219-742-11	CARBON 47	5% 1/2W
R018	1-216-025-91	RES,CHIP 100	5% 1/10W	R161	1-215-394-00	METAL 75	1% 1/4W
R020	1-216-017-91	RES,CHIP 47	5% 1/10W	R204	1-216-009-91	RES,CHIP 22	5% 1/10W
R021	1-216-017-91	RES,CHIP 47	5% 1/10W	R206	1-216-071-00	RES,CHIP 8.2K	5% 1/10W
R022	1-216-025-91	RES,CHIP 100	5% 1/10W	R207	1-216-675-91	METAL CHIP 10K	0.5% 1/10W
R023	1-216-049-91	RES,CHIP 1K	5% 1/10W	R208	1-216-049-91	RES,CHIP 1K	5% 1/10W
R024	1-216-061-00	RES,CHIP 3.3K	5% 1/10W	R209	1-216-041-00	RES,CHIP 470	5% 1/10W
R025	1-216-061-00	RES,CHIP 3.3K	5% 1/10W	R210	1-216-071-00	RES,CHIP 8.2K	5% 1/10W
R027	1-216-057-91	RES,CHIP 2.2K	5% 1/10W	R211	1-249-403-11	CARBON 68	5% 1/4W F
R029	1-216-097-91	RES,CHIP 100K	5% 1/10W	R215	1-216-107-00	RES,CHIP 270K	5% 1/10W
R030	1-216-025-91	RES,CHIP 100	5% 1/10W	R217	1-216-025-91	RES,CHIP 100	5% 1/10W
R031	1-216-049-91	RES,CHIP 1K	5% 1/10W	R218	1-216-019-00	RES,CHIP 56	5% 1/10W
R032	1-216-025-91	RES,CHIP 100	5% 1/10W	R219	1-216-113-00	RES,CHIP 470K	5% 1/10W
R033	1-216-057-00	RES,CHIP 2.2K	5% 1/10W	R220	1-216-113-00	RES,CHIP 470K	5% 1/10W
R034	1-216-295-91	SHORT 0		R222	1-216-113-00	RES,CHIP 470K	5% 1/10W
R040	1-216-129-00	RES,CHIP 2.2M	5% 1/10W	R223	1-216-037-00	RES,CHIP 330	5% 1/10W
				R230	1-216-025-91	RES,CHIP 100	5% 1/10W
				R233	1-216-295-91	SHORT 0	
				R251	1-219-742-11	CARBON 47	5% 1/2W
				R261	1-215-394-00	METAL 75	1% 1/4W



# CPD-E400/E400E/E400P



REF.NO.	PART NO.	DESCRIPTION	REMARK	REF.NO.	PART NO.	DESCRIPTION	REMARK
R304	1-216-009-91	RES,CHIP	22 5% 1/10W	C500	1-163-259-91	CERAMIC CHIP 220pF	5% 50V
R306	1-216-071-00	RES,CHIP	8.2K 5% 1/10W	C501	1-163-038-91	CERAMIC CHIP 0.1μF	25V
R307	1-216-675-91	METAL CHIP	10K 0.5% 1/10W	C503	1-137-370-11	MYLAR 0.01μF	5% 50V
R308	1-216-049-91	RES,CHIP	1K 5% 1/10W	C504	1-137-368-11	MYLAR 0.0047μF	5% 50V
R309	1-216-041-00	RES,CHIP	470 5% 1/10W	C505	1-128-729-91	ELECT 330μF	20% 25V
R310	1-216-071-00	RES,CHIP	8.2K 5% 1/10W	C506	1-127-810-51	ELECT MELF 22μF	20% 250V
R311	1-249-403-11	CARBON	68 5% 1/4W F	C507	1-136-187-11	MYLAR 0.047μF	10% 250V
R315	1-216-107-00	RES,CHIP	270K 5% 1/10W	C508	1-117-959-11	FILM 4700pF	3% 1.8KV
R317	1-216-025-91	RES,CHIP	100 5% 1/10W	C509	1-107-444-11	CERAMIC 100pF	5% 2KV
R318	1-216-019-00	RES,CHIP	56 5% 1/10W	C510	1-136-684-51	MYLAR 0.0022μF	10% 100V
R319	1-216-113-00	RES,CHIP	470K 5% 1/10W	C511	1-163-038-91	CERAMIC CHIP 0.1μF	25V
R320	1-216-113-00	RES,CHIP	470K 5% 1/10W	C512	1-102-114-00	CERAMIC 470pF	10% 50V
R322	1-216-113-00	RES,CHIP	470K 5% 1/10W	C513	1-163-038-91	CERAMIC CHIP 0.1μF	25V
R323	1-216-037-00	RES,CHIP	330 5% 1/10W	C514	1-137-368-11	MYLAR 0.0047μF	5% 50V
R330	1-216-025-91	RES,CHIP	100 5% 1/10W	C515	1-163-021-91	CERAMIC CHIP 0.01μF	10% 50V
R333	1-216-295-91	SHORT	0	C516	1-126-382-11	ELECT 100μF	20% 16V
R351	1-219-742-11	CARBON	47 5% 1/2W	C517	1-163-263-11	CERAMIC CHIP 330pF	5% 50V
R361	1-215-394-00	METAL	75 1% 1/4W	C518	1-164-004-11	CERAMIC CHIP 0.1μF	10% 25V
<SPARK GAP>				C520	1-163-024-00	CERAMIC CHIP 0.018μF	10% 50V
SG001	1-519-422-11	GAP, SPARK		C521	1-163-037-11	CERAMIC CHIP 0.022μF	10% 50V
SG002	1-576-354-21	GAP, DISCHARGE		C522	1-126-965-11	ELECT 22μF	20% 50V
SG101	1-576-354-21	GAP, DISCHARGE		C523	1-163-021-91	CERAMIC CHIP 0.01μF	10% 50V
SG201	1-576-354-21	GAP, DISCHARGE		C524	1-126-382-11	ELECT 100μF	20% 16V
SG301	1-576-354-21	GAP, DISCHARGE		C525	1-163-038-91	CERAMIC CHIP 0.1μF	25V
<CRYSTAL>				C527	1-163-019-00	CERAMIC CHIP 0.0068μF	10% 50V
X001	1-781-472-21	VIBRATOR, CERAMIC (8MHZ)		C528	1-130-489-00	MYLAR 0.033μF	5% 50V
*****				C529	1-137-370-11	MYLAR 0.01μF	5% 50V
D BOARD, COMPLETE				C530	1-163-038-91	CERAMIC CHIP 0.1μF	25V
*****				C531	1-163-038-91	CERAMIC CHIP 0.1μF	25V
1-533-223-11	HOLDER, FUSE (F601)			C532	1-107-906-11	ELECT 10μF	20% 50V
3-710-578-01	COVER, VOLUME, 6 MOLD (RV901)			C533	1-163-037-11	CERAMIC CHIP 0.022μF	10% 50V
4-061-192-11	SHEET, INSULATING (Q505)			C534	1-163-038-91	CERAMIC CHIP 0.1μF	25V
4-382-854-01	SCREW (M3X8), P, SW (+) (D614, D619, IC401, IC502, IC604, IC605, IC609, IC610, IC703, Q506, Q511, Q512, Q513, Q605, Q704, Q705, Q901, Q902, R510)			C535	1-164-004-11	CERAMIC CHIP 0.1μF	10% 25V
4-382-854-11	SCREW (M3X10), P, SW (+) (D504, D620, D622, Q505)			C536	1-107-665-11	ELECT 0.47μF	20% 400V
4-382-854-21	SCREW (M3X14), P, SW (+) (IC702)			C537	1-107-770-11	FILM 0.16μF	3% 400V
7-685-881-09	SCREW +BVTT 4X8 (S)			C538	1-107-651-11	ELECT 4.7μF	20% 250V
<CAPACITOR>				C539	1-117-673-11	FILM 1.5μF	5% 250V
C401	1-128-730-91	ELECT	470μF 20% 25V	C540	1-107-888-11	ELECT 47μF	20% 25V
C402	1-106-228-00	MYLAR	0.22μF 10% 100V	C541	1-109-844-11	FILM 0.68μF	5% 250V
C403	1-128-749-91	ELECT	220μF 20% 50V	C542	1-163-021-91	CERAMIC CHIP 0.01μF	10% 50V
C404	1-128-730-91	ELECT	470μF 20% 25V	C543	1-117-665-11	FILM 0.33μF	5% 250V
C406	1-137-366-11	MYLAR	0.0022μF 5% 50V	C544	1-163-021-91	CERAMIC CHIP 0.01μF	10% 50V
C407	1-164-182-11	CERAMIC CHIP	0.0033μF 10% 50V	C545	1-117-661-21	FILM 0.15μF	5% 250V
C409	1-126-968-11	ELECT	100μF 20% 50V	C546	1-163-021-91	CERAMIC CHIP 0.01μF	10% 50V
C500	1-163-259-91	CERAMIC CHIP	220pF 5% 50V	C547	1-119-860-11	FILM 0.082μF	5% 250V
C501	1-163-038-91	CERAMIC CHIP	0.1μF 25V	C548	1-163-021-91	CERAMIC CHIP 0.01μF	10% 50V
C503	1-137-370-11	MYLAR	0.01μF 5% 50V	C549	1-117-953-91	FILM 0.033μF	5% 400V
C504	1-137-368-11	MYLAR	0.0047μF 5% 50V	C550	1-163-021-91	CERAMIC CHIP 0.01μF	10% 50V
C505	1-128-729-91	ELECT	330μF 20% 25V	C551	1-163-251-11	CERAMIC CHIP 100pF	5% 50V
C506	1-127-810-51	ELECT MELF	22μF 20% 250V	C553	1-163-017-00	CERAMIC CHIP 0.0047μF	10% 50V
C507	1-136-187-11	MYLAR	0.047μF 10% 250V	C554	1-163-259-91	CERAMIC CHIP 220pF	5% 50V
C508	1-117-959-11	FILM	4700pF 3% 1.8KV	C555	1-137-194-81	MYLAR 0.47μF	5% 50V
C509	1-107-444-11	CERAMIC	100pF 5% 2KV	C556	1-163-021-91	CERAMIC CHIP 0.01μF	10% 50V
C510	1-136-684-51	MYLAR	0.0022μF 10% 100V	C557	1-126-935-11	ELECT 470μF	20% 16V
C511	1-163-038-91	CERAMIC CHIP	0.1μF 25V	C558	1-163-007-11	CERAMIC CHIP 680pF	10% 50V
C512	1-102-114-00	CERAMIC	470pF 10% 50V	C559	1-163-038-91	CERAMIC CHIP 0.1μF	25V
C513	1-163-038-91	CERAMIC CHIP	0.1μF 25V				

The components identified  $\Delta$  marked are critical for safety.  
Replace only with the part number specified.

Les composants identifiés par la marque  $\Delta$  sont critiques pour la sécurité.  
Ne les remplacer que par une pièce portant le numéro spécifié.

CPD-E400/E400E/E400P



REF.NO.	PART NO.	DESCRIPTION	REMARK	REF.NO.	PART NO.	DESCRIPTION	REMARK
C560	1-109-982-11	CERAMIC CHIP 1 $\mu$ F	10% 10V	C657	1-162-318-11	CERAMIC 0.001 $\mu$ F	10% 500V
C562	1-163-001-11	CERAMIC CHIP 220pF	10% 50V	C658	1-162-815-11	CERAMIC 47pF	5% 500V
C563	1-113-340-11	ELECT 47 $\mu$ F	20% 25V	C659	1-136-177-00	MYLAR 1 $\mu$ F	5% 50V
C564	1-115-339-11	CERAMIC CHIP 0.1 $\mu$ F	10% 50V	C701	1-163-003-11	CERAMIC CHIP 330pF	10% 50V
C565	1-163-275-11	CERAMIC CHIP 0.001 $\mu$ F	5% 50V	C703	1-163-003-11	CERAMIC CHIP 330pF	10% 50V
#2 C607	1-216-295-11	SHORT 0 [E400/E400E]		C704	1-130-495-00	MYLAR 0.1 $\mu$ F	5% 50V
#2 C607	1-115-339-11	CERAMIC CHIP 0.1 $\mu$ F	10% 50V [E400P]	C705	1-164-004-11	CERAMIC CHIP 0.1 $\mu$ F	10% 25V
C608	1-115-339-11	CERAMIC CHIP 0.1 $\mu$ F	10% 50V	C706	1-130-495-00	MYLAR 0.1 $\mu$ F	5% 50V
C609	1-117-703-11	CERAMIC 0.0047 $\mu$ F	20% 250V	C707	1-126-942-61	ELECT 1000 $\mu$ F	20% 25V
C610	1-117-769-91	CERAMIC 680pF	10% 2KV	C708	1-126-942-61	ELECT 1000 $\mu$ F	20% 25V
C611	1-113-608-11	ELECT(BLOCK) 470 $\mu$ F	20% 400V	C711	1-163-113-00	CERAMIC CHIP 68pF	5% 50V
C612	1-117-953-91	FILM 0.033 $\mu$ F	5% 400V	C712	1-163-113-00	CERAMIC CHIP 68pF	5% 50V
C613	1-104-664-11	ELECT 47 $\mu$ F	20% 25V	C713	1-163-021-91	CERAMIC CHIP 0.01 $\mu$ F	10% 50V
#2 C614	1-115-339-11	CERAMIC CHIP 0.1 $\mu$ F	10% 50V [E400/E400E]	C714	1-126-960-11	ELECT 1 $\mu$ F	20% 50V
#2 C614	1-163-021-91	CERAMIC CHIP 0.01 $\mu$ F	10% 50V [E400P]	C716	1-136-177-00	MYLAR 1 $\mu$ F	5% 50V
C615	1-163-037-11	CERAMIC CHIP 0.022 $\mu$ F	10% 50V	C717	1-164-004-11	CERAMIC CHIP 0.1 $\mu$ F	10% 25V
C616	1-102-228-00	CERAMIC 470pF	10% 500V	C718	1-163-038-91	CERAMIC CHIP 0.1 $\mu$ F	25V
C617	1-117-769-91	CERAMIC 680pF	10% 2KV	C719	1-163-038-91	CERAMIC CHIP 0.1 $\mu$ F	25V
C618	1-164-004-11	CERAMIC CHIP 0.1 $\mu$ F	10% 25V	C720	1-163-021-91	CERAMIC CHIP 0.01 $\mu$ F	10% 50V
C619	1-163-019-00	CERAMIC CHIP 0.0068 $\mu$ F	10% 50V	C721	1-128-562-11	ELECT 47 $\mu$ F	20% 100V
C620	1-128-551-11	ELECT 22 $\mu$ F	20% 25V	C723	1-128-561-91	ELECT 33 $\mu$ F	20% 100V
C621	1-131-723-21	ELECT(BLOCK) 220 $\mu$ F	20% 250V	C724	1-162-134-11	CERAMIC 470pF	10% 2KV
C622	1-164-161-11	CERAMIC CHIP 0.0022 $\mu$ F	10% 50V	C725	1-126-965-11	ELECT 22 $\mu$ F	20% 50V
C623	1-107-933-11	ELECT 100 $\mu$ F	20% 100V	C726	1-163-038-91	CERAMIC CHIP 0.1 $\mu$ F	25V
C624	1-104-666-11	ELECT 220 $\mu$ F	20% 25V	C727	1-163-038-91	CERAMIC CHIP 0.1 $\mu$ F	25V
C625	1-115-789-11	ELECT 0.001F	20% 25V	C728	1-163-017-00	CERAMIC CHIP 0.0047 $\mu$ F	10% 50V
C626	1-115-791-11	ELECT 0.0018F	20% 25V	C729	1-163-017-00	CERAMIC CHIP 0.0047 $\mu$ F	10% 50V
C627	1-115-789-11	ELECT 0.001F	20% 25V	C730	1-163-017-00	CERAMIC CHIP 0.0047 $\mu$ F	10% 50V
C628	1-107-890-11	ELECT 2200 $\mu$ F	20% 25V	C731	1-163-017-00	CERAMIC CHIP 0.0047 $\mu$ F	10% 50V
C629	1-126-935-11	ELECT 470 $\mu$ F	20% 16V	C732	1-163-021-91	CERAMIC CHIP 0.01 $\mu$ F	10% 50V
C630	1-126-935-11	ELECT 470 $\mu$ F	20% 16V	C901	1-104-665-11	ELECT 100 $\mu$ F	20% 25V
C631	1-128-526-11	ELECT 100 $\mu$ F	20% 25V	C902	1-163-021-91	CERAMIC CHIP 0.01 $\mu$ F	10% 50V
C632	1-104-653-11	ELECT 220 $\mu$ F	20% 16V	C903	1-107-904-11	ELECT 3.3 $\mu$ F	20% 50V
C633	1-126-934-11	ELECT 220 $\mu$ F	20% 10V	C904	1-115-339-11	CERAMIC CHIP 0.1 $\mu$ F	10% 50V
C634	1-164-004-11	CERAMIC CHIP 0.1 $\mu$ F	10% 25V	C905	1-163-133-00	CERAMIC CHIP 470pF	5% 50V
C635	1-126-965-11	ELECT 22 $\mu$ F	20% 50V	C906	1-163-251-11	CERAMIC CHIP 100pF	5% 50V
C636 $\Delta$	1-113-900-51	CERAMIC 470pF	10% 250V	C907	1-163-275-11	CERAMIC CHIP 0.001 $\mu$ F	5% 50V
C637 $\Delta$	1-113-900-51	CERAMIC 470pF	10% 250V	C908	1-164-505-11	CERAMIC CHIP 2.2 $\mu$ F	16V
C638 $\Delta$	1-104-708-51	MYLAR 0.47 $\mu$ F	20% 250V	C909	1-104-665-11	ELECT 100 $\mu$ F	20% 25V
#2 C639 $\Delta$	1-104-708-51	MYLAR 0.47 $\mu$ F	20% 250V [E400/E400E]	C910	1-163-259-91	CERAMIC CHIP 220pF	5% 50V
C640	1-164-004-11	CERAMIC CHIP 0.1 $\mu$ F	10% 25V	C911	1-163-243-11	CERAMIC CHIP 47pF	5% 50V
C641	1-163-007-11	CERAMIC CHIP 680pF	10% 50V	C912	1-163-021-91	CERAMIC CHIP 0.01 $\mu$ F	10% 50V
C642	1-163-017-00	CERAMIC CHIP 0.0047 $\mu$ F	10% 50V	C913	1-119-748-11	ELECT 33 $\mu$ F	20% 400V
C644	1-136-187-11	MYLAR 0.047 $\mu$ F	10% 250V	C914	1-136-187-11	MYLAR 0.047 $\mu$ F	10% 250V
C645	1-126-934-11	ELECT 220 $\mu$ F	20% 16V	C915	1-137-367-11	MYLAR 0.0033 $\mu$ F	5% 50V
C646	1-107-882-91	ELECT 100 $\mu$ F	20% 16V	C916	1-117-665-11	FILM 0.33 $\mu$ F	5% 250V
C647	1-107-882-91	ELECT 100 $\mu$ F	20% 16V	C917	1-163-038-91	CERAMIC CHIP 0.1 $\mu$ F	25V
C648	1-107-906-11	ELECT 10 $\mu$ F	20% 50V	C918	1-117-626-11	FILM 2000pF	3% 1.2KV
C650	1-162-117-00	CERAMIC 100pF	10% 500V	C919	1-115-349-51	CERAMIC 0.01 $\mu$ F	2KV
C653	1-126-942-61	ELECT 1000 $\mu$ F	20% 25V	C920	1-115-349-51	CERAMIC 0.01 $\mu$ F	2KV
C654	1-104-666-11	ELECT 220 $\mu$ F	20% 25V	C921	1-163-038-91	CERAMIC CHIP 0.1 $\mu$ F	25V
C656	1-104-664-11	ELECT 47 $\mu$ F	20% 25V	C922	1-126-963-11	ELECT 4.7 $\mu$ F	20% 50V
				C923	1-126-964-11	ELECT 10 $\mu$ F	20% 50V
				C924	1-104-665-11	ELECT 100 $\mu$ F	20% 25V
				C925	1-137-370-11	MYLAR 0.01 $\mu$ F	5% 50V
				C926	1-106-220-00	MYLAR 0.1 $\mu$ F	10% 100V

# CPD-E400/E400E/E400P



Les composants identifiés par la marque  $\Delta$  sont critiques pour la sécurité.  
Ne les remplacer que par une pièce portant le numéro spécifié.

The components identified  $\Delta$  marked are critical for safety.  
Replace only with the part number specified.

REF.NO.	PART NO.	DESCRIPTION	REMARK	REF.NO.	PART NO.	DESCRIPTION	REMARK
C927	1-106-351-00	MYLAR 0.0022 $\mu$ F	20% 200V	D514	8-719-109-81	ZENER DIODE RD4.7ESB2	
C929	1-126-965-11	ELECT 22 $\mu$ F	20% 50V	D515	8-719-073-01	DIODE MA111-(K8).S0	
C930	1-137-370-11	MYLAR 0.01 $\mu$ F	5% 50V	D516	8-719-951-30	DIODE ERA91-02	
C931	1-164-005-11	CERAMIC CHIP 0.47 $\mu$ F	25V	D517	8-719-978-65	ZENER DIODE DTZ-TT11-15B	
C1006	1-163-038-91	CERAMIC CHIP 0.1 $\mu$ F	25V	D518	8-719-110-17	ZENER DIODE RD10ESB2	
C1013	1-126-926-11	ELECT 1000 $\mu$ F	20% 10V	D519	8-719-109-81	ZENER DIODE DTZ4.7C	
C1024	1-163-227-11	CERAMIC CHIP 10pF	0.5pF 50V	#2 D607	8-719-073-01	DIODE MA111-(K8).S0 [E400P]	
C1025	1-163-227-11	CERAMIC CHIP 10pF	0.5pF 50V	D608	8-719-061-42	DIODE 1N4148S-26TP	
C1026	1-163-038-91	CERAMIC CHIP 0.1 $\mu$ F	25V	D609	8-719-053-19	DIODE UF4007G23	
C1030	1-164-222-11	CERAMIC CHIP 0.22 $\mu$ F	25V	D610	8-719-921-40	DIODE MTZJ-4.7C	
C1031	1-164-004-11	CERAMIC CHIP 0.1 $\mu$ F	10% 25V	D611	8-719-053-19	DIODE UF4007G23	
C1036	1-163-038-91	CERAMIC CHIP 0.1 $\mu$ F	25V	D612	8-719-110-49	ZENER DIODE RD18ESB2	
C1037	1-164-004-11	CERAMIC CHIP 0.1 $\mu$ F	10% 25V	D613	8-719-300-76	DIODE RH-1A	
C1038	1-163-021-91	CERAMIC CHIP 0.01 $\mu$ F	10% 50V	D614	8-719-067-68	DIODE FMC-26UA	
C1042	1-163-243-11	CERAMIC CHIP 47pF	5% 50V	D615	8-719-053-19	DIODE UF4007G23	
C1046	1-163-243-11	CERAMIC CHIP 47pF	5% 50V	D616	8-719-076-20	DIODE BT149G-412-OT359	
C1047	1-163-243-11	CERAMIC CHIP 47pF	5% 50V	D617	8-719-061-42	DIODE 1N4148S-26TP	
C1050	1-164-004-11	CERAMIC CHIP 0.1 $\mu$ F	10% 25V	D618	8-719-069-63	DIODE ERB38-06V1	
C1056	1-163-243-11	CERAMIC CHIP 47pF	5% 50V	D619	8-719-058-38	DIODE FMN-G12S	
C1057	1-163-243-11	CERAMIC CHIP 47pF	5% 50V	D620	8-719-510-41	DIODE D10SC9M	
C1061	1-163-038-91	CERAMIC CHIP 0.1 $\mu$ F	25V	D621	8-719-979-58	DIODE EGP10D	
C1062	1-164-004-11	CERAMIC CHIP 0.1 $\mu$ F	10% 25V	D622	8-719-074-79	DIODE YG911S2R	
C1063	1-115-339-11	CERAMIC CHIP 0.1 $\mu$ F	10% 50V	D623	8-719-979-58	DIODE EGP10D	
C1064	1-164-004-11	CERAMIC CHIP 0.1 $\mu$ F	10% 25V	D624	8-719-979-58	DIODE EGP10D	
		<CONNECTOR>		D625 $\Delta$	8-719-510-63	DIODE D4SB60L-F	
CN501*	1-580-798-11	CONNECTOR PIN (DY) 6P		D626	8-719-061-42	DIODE 1N4148S-26TP	
CN600*	1-691-960-11	PIN, CONNECTOR (PC BOARD) 3P		D627	8-719-110-08	ZENER DIODE RD8.2ESB2	
CN601*	1-580-689-11	PIN, CONNECTOR (PC BOARD) 4P		D628	8-719-061-42	DIODE 1N4148S-26TP	
CN603*	1-564-510-11	PLUG, CONNECTOR 7P		D629	8-719-073-01	DIODE MA111-(K8).S0	
CN701*	1-564-511-11	PLUG, CONNECTOR 8P		D630	8-719-110-41	ZENER DIODE RD15ESB2	
CN702*	1-564-506-11	PLUG, CONNECTOR 3P		D634	8-719-061-42	DIODE 1SS119	
CN901	1-695-915-11	TAB (CONTACT)		D635	8-719-061-42	DIODE 1SS119	
CN1001*	1-508-879-11	BASE POST		D701	8-719-061-42	DIODE 1N4148S-26TP	
CN1002*	1-564-511-11	PLUG, CONNECTOR 8P		D702	8-719-061-42	DIODE 1N4148S-26TP	
CN1003*	1-564-515-11	PLUG, CONNECTOR 12P		D703	8-719-061-42	DIODE 1N4148S-26TP	
CN1004*	1-564-509-11	PLUG, CONNECTOR 6P		D705	8-719-158-49	ZENER DIODE RD12SB2	
		<DIODE>		D901	8-719-073-01	DIODE MA111-(K8).S0	
D401	8-719-979-58	DIODE EGP10D		D903	8-719-073-01	DIODE MA111-(K8).S0	
D402	8-719-158-15	ZENER DIODE RD5.6SB		D904	8-719-073-01	DIODE MA111-(K8).S0	
D405	8-719-061-42	DIODE 1N4148S-26TP		D906	8-719-978-65	ZENER DIODE DTZ-TT11-15B	
D501	8-719-110-47	ZENER DIODE RD18ESB		D907	8-719-052-86	DIODE D2L40-TA	
D502	8-719-981-00	DIODE ERC81-004		D908	8-719-073-01	DIODE MA111-(K8).S0	
D503	8-719-110-47	ZENER DIODE RD18ESB		D909	8-719-978-65	ZENER DIODE DTZ-TT11-15B	
D504	8-719-061-21	DIODE FMQ-G5FMS		D910	8-719-028-72	DIODE RGP02-17EL-6433	
D505	8-719-052-86	DIODE D2L40-TA		D911	8-719-028-72	DIODE RGP02-17EL-6433	
D506	8-719-976-96	ZENER DIODE DTZ4.7C		D912	8-719-110-46	ZENER DIODE RD16ESB3	
D507	8-719-073-01	DIODE MA111-(K8).S0		D913	8-719-110-46	ZENER DIODE RD16ESB3	
D508	8-719-073-01	DIODE MA111-(K8).S0		D914	8-719-970-83	DIODE HSS82	
D509	8-719-073-01	DIODE MA111-(K8).S0		D915	8-719-109-85	ZENER DIODE RD5.1ESB2	
D510	8-719-073-01	DIODE MA111-(K8).S0		D916	8-719-158-49	ZENER DIODE RD12SB2	
D511	8-719-073-01	DIODE MA111-(K8).S0		D917	8-719-929-15	ZENER DIODE HZS9.1NB2	
D512	8-719-073-01	DIODE MA111-(K8).S0		D920	8-719-158-15	ZENER DIODE RD5.6SB	
				D921	8-719-158-15	ZENER DIODE RD5.6SB	
				D1001	8-719-158-15	ZENER DIODE RD5.6SB	
				D1003	1-218-772-11	METAL CHIP 680K 0.5% 1/10W	
				D1007	8-719-158-15	ZENER DIODE RD5.6SB	

The components identified  $\Delta$  marked are critical for safety.  
Replace only with the part number specified.

Les composants identifiés par la marque  $\Delta$  sont critiques pour la sécurité.  
Ne les remplacer que par une pièce portant le numéro spécifié.

CPD-E400/E400E/E400P



REF.NO.	PART NO.	DESCRIPTION	REMARK	REF.NO.	PART NO.	DESCRIPTION	REMARK
D1008	8-719-158-15	ZENER DIODE RD5.6SB		JR005	1-216-295-91	SHORT	0
D1009	8-719-158-15	ZENER DIODE RD5.6SB		JR006	1-216-296-91	SHORT	0
D1010	8-719-158-15	ZENER DIODE RD5.6SB		JR007	1-216-295-91	SHORT	0
D1011	8-719-158-15	ZENER DIODE RD5.6SB		JR008	1-216-296-91	SHORT	0
D1012	8-719-158-15	ZENER DIODE RD5.6SB		JR009	1-216-296-91	SHORT	0
D1013	8-719-158-15	ZENER DIODE RD5.6SB		JR010	1-216-296-91	SHORT	0
D1014	8-719-158-15	ZENER DIODE RD5.6SB		JR011	1-216-296-91	SHORT	0
D1018	8-719-073-01	DIODE MA111-(K8),S0		JR015	1-216-296-91	SHORT	0
D1021	8-719-062-51	DIODE 1PS226-115		JR016	1-216-296-91	SHORT	0
D1022	8-719-062-51	DIODE 1PS226-115		JR017	1-216-296-91	SHORT	0
D1024	8-719-073-01	DIODE MA111-(K8),S0		JR019	1-216-296-91	SHORT	0
D1025	8-719-158-15	ZENER DIODE RD5.6SB		JR020	1-216-296-91	SHORT	0
		<FUSE>		JR021	1-216-296-91	SHORT	0
F601	$\Delta$ 1-576-233-11	FUSE (H.B.C.) (6.3A/250V)		JR022	1-216-295-91	SHORT	0
		<FERRITE BEAD>		JR023	1-216-296-91	SHORT	0
FB501	1-412-911-11	FERRITE	1.1 $\mu$ H	JR024	1-216-295-91	SHORT	0
FB502	1-543-960-22	FERRITE		JR025	1-216-295-91	SHORT	0
FB901	1-412-911-11	FERRITE	1.1 $\mu$ H	JR026	1-216-296-91	SHORT	0
FB1000	1-216-295-91	SHORT	0	JR027	1-216-295-91	SHORT	0
FB1001	1-216-025-91	RES,CHIP	100 5% 1/10W	JR028	1-216-295-91	SHORT	0
FB1002	1-216-025-91	RES,CHIP	100 5% 1/10W	JR029	1-216-295-91	SHORT	0
FB1004	1-216-295-91	SHORT	0	JR030	1-216-296-91	SHORT	0
		<IC>		JR031	1-216-295-91	SHORT	0
IC401	8-759-593-28	IC LA78040		JR032	1-216-296-91	SHORT	0
IC501	8-759-585-82	IC BA9759F-E2		JR033	1-216-296-91	SHORT	0
IC502	8-759-803-42	IC LA6500-FA		JR034	1-216-296-91	SHORT	0
IC503	8-759-100-96	IC $\mu$ PC4558G2		JR035	1-216-296-91	SHORT	0
IC603	8-759-594-75	IC TEA1504/N2		JR036	1-216-295-91	SHORT	0
IC604	8-759-637-83	IC PQ12RD8S		JR037	1-216-296-91	SHORT	0
IC605	8-759-496-15	IC BA05ST-V5		JR038	1-216-296-91	SHORT	0
IC607	8-749-016-35	IC TLP621D4-Y-LF2T		JR039	1-216-296-91	SHORT	0
IC608	8-759-586-17	IC TL1431CZ-AP		JR040	1-216-295-91	SHORT	0
IC609	8-759-450-47	IC BA05T		JR042	1-216-296-91	SHORT	0
IC610	8-759-592-79	IC BA00AST-V5		JR046	1-216-296-91	SHORT	0
IC701	8-759-822-38	IC LA6510		JR050	1-216-295-91	SHORT	0
IC702	8-749-015-00	IC STK391-110		JR051	1-216-296-91	SHORT	0
IC703	8-759-803-42	IC LA6500-FA		JR052	1-216-296-91	SHORT	0
IC901	8-759-585-81	IC BA9758FS-E2		JR602	1-216-295-91	SHORT	0
IC1001	8-759-639-51	IC CXD9523S/JCN (Ver. 1.2)		JR603	1-216-295-91	SHORT	0
IC1003	8-759-420-77	IC PST574CMT-T1		JR604	1-216-295-91	SHORT	0
IC1005	8-759-641-86	IC BR24C16F-E2		JR605	1-216-295-91	SHORT	0
		<CHIP CONDUCTOR>		JR606	1-216-295-91	SHORT	0
JR43	1-216-296-91	SHORT	0			<COIL>	
JR45	1-216-295-91	SHORT	0	L501	1-412-541-21	INDUCTOR	220 $\mu$ H
#2 JR54	1-216-295-91	SHORT	0 [E400P]	L502	1-419-299-11	COIL, HORIZONTAL LINEARITY	
JR55	1-216-296-91	SHORT	0	L503	1-419-298-11	COIL, HORIZONTAL CENTER	
JR002	1-216-296-91	SHORT	0	L504	1-406-675-11	INDUCTOR	4.7mH
JR004	1-216-296-91	SHORT	0	L505	1-406-675-11	INDUCTOR	4.7mH
				L506	1-406-675-11	INDUCTOR	4.7mH
				L507	1-412-537-31	INDUCTOR	100 $\mu$ H
				#2 L601	1-419-653-11	INDUCTOR	56mH [E400P]
				L603	1-412-537-31	INDUCTOR	100 $\mu$ H
				L604	1-406-665-11	INDUCTOR	100 $\mu$ H
				L606	1-406-665-11	INDUCTOR	100 $\mu$ H

# CPD-E400/E400E/E400P



REF.NO.	PART NO.	DESCRIPTION	REMARK	REF.NO.	PART NO.	DESCRIPTION	REMARK
L607	1-414-158-11	INDUCTOR	2.2μH	R417	1-216-113-00	RES,CHIP	470K 5% 1/10W
L608	1-414-488-21	INDUCTOR	1.5μH	R418	1-216-105-91	RES,CHIP	220K 5% 1/10W
L901	1-412-537-31	INDUCTOR	100μH	R501	1-216-049-91	RES,CHIP	1K 5% 1/10W
L902	1-406-659-11	INDUCTOR	10μH	R502	1-216-025-91	RES,CHIP	100 5% 1/10W
<FILTER>				R503	1-216-033-00	RES,CHIP	220 5% 1/10W
LF602△	1-429-180-11	TRANSFORMER, LINE FILTER		R504	1-216-073-00	RES,CHIP	10K 5% 1/10W
<TRANSISTOR>				R505	1-216-081-00	RES,CHIP	22K 5% 1/10W
Q501	8-729-120-28	TRANSISTOR 2SC1623-L5L6		R506	1-247-807-31	CARBON	100 5% 1/4W
Q502	8-729-901-87	TRANSISTOR 2SC2411K-CQ		R507	1-247-863-91	CARBON	22K 5% 1/4W
Q503	8-729-026-50	TRANSISTOR 2SA1037AK-T146-QR		R508	1-215-861-00	METAL OXIDE	47 5% 1W F
Q504	8-729-042-34	TRANSISTOR IRFU110A		R509	1-249-381-11	CARBON	1 5% 1/4W F
Q505	8-729-050-12	TRANSISTOR 2SC5445(LBSONY1)		R510	1-219-677-11	METAL	1.8 5% 10W
Q506	8-729-043-63	TRANSISTOR IRFI9634G-LF35		R511	1-249-377-11	CARBON	0.47 5% 1/4W F
Q507	8-729-120-28	TRANSISTOR 2SC1623-L5L6		R512	1-214-842-11	METAL	120 1% 1/2W
Q508	8-729-901-87	TRANSISTOR 2SC2411K-CQ		R513	1-216-423-11	METAL OXIDE	27 5% 1W F
Q509	8-729-901-97	TRANSISTOR 2SA1036K-Q		R514	1-249-397-11	CARBON	22 5% 1/4W F
Q510	8-729-119-78	TRANSISTOR 2SC2785-HFE		R515	1-249-425-11	CARBON	4.7K 5% 1/4W
Q511	8-729-043-41	TRANSISTOR 2SK2098-01MR-F119		R516	1-249-425-11	CARBON	4.7K 5% 1/4W
Q512	8-729-043-41	TRANSISTOR 2SK2098-01MR-F119		R517	1-216-089-91	RES,CHIP	47K 5% 1/10W
Q513	8-729-043-41	TRANSISTOR 2SK2098-01MR-F119		R518	1-216-033-00	RES,CHIP	220 5% 1/10W
Q514	8-729-043-41	TRANSISTOR 2SK2098-01MR-F119		R519	1-216-025-91	RES,CHIP	100 5% 1/10W
Q515	8-729-043-41	TRANSISTOR 2SK2098-01MR-F119		R520	1-216-033-00	RES,CHIP	220 5% 1/10W
Q516	8-729-043-41	TRANSISTOR 2SK2098-01MR-F119		R521	1-247-807-31	CARBON	100 5% 1/4W
Q517	8-729-140-50	TRANSISTOR 2SC3209LK		R522	1-216-057-00	RES,CHIP	2.2K 5% 1/10W
Q519	8-729-026-49	TRANSISTOR 2SA1037AK-T146-R		R523	1-216-683-11	METAL CHIP	22K 0.5% 1/10W
Q605	8-729-050-14	TRANSISTOR 2SK3265 (LB2SONY)		R524	1-216-663-11	METAL CHIP	3.3K 0.5% 1/10W
Q606	8-729-043-27	TRANSISTOR PDTC114EK-115		R525	1-216-657-11	METAL CHIP	1.8K 0.5% 1/10W
Q607	8-729-119-78	TRANSISTOR 2SC2785-HFE		R526	1-216-691-11	METAL CHIP	47K 0.5% 1/10W
Q608	8-729-029-92	TRANSISTOR DTC143ESA		R527	1-216-683-11	METAL CHIP	22K 0.5% 1/10W
Q609	8-729-119-78	TRANSISTOR 2SC2785-HFE		R528	1-216-683-11	METAL CHIP	22K 0.5% 1/10W
Q701	8-729-800-32	TRANSISTOR 2SC2362K-G		R529	1-216-099-00	RES,CHIP	120K 5% 1/10W
Q702	8-729-178-43	TRANSISTOR 2SC2784-E		R530	1-216-663-11	METAL CHIP	3.3K 0.5% 1/10W
Q703	8-729-204-91	TRANSISTOR 2SA1049-GR		R531	1-216-661-11	METAL CHIP	2.7K 0.5% 1/10W
Q704	8-729-207-82	TRANSISTOR 2SC3421-Y		R532	1-216-073-00	RES,CHIP	10K 5% 1/10W
Q705	8-729-207-89	TRANSISTOR 2SA1358-Y		R533	1-216-057-00	RES,CHIP	2.2K 5% 1/10W
Q706	8-729-031-89	TRANSISTOR 2SC3941A-Q (TA)		R535	1-216-683-11	METAL CHIP	22K 0.5% 1/10W
Q901	8-729-043-63	TRANSISTOR IRFI9634G-LF35		R536	1-216-683-11	METAL CHIP	22K 0.5% 1/10W
Q902	8-729-041-45	TRANSISTOR FS5KM-16A		R537	1-216-683-11	METAL CHIP	22K 0.5% 1/10W
Q903	8-729-120-28	TRANSISTOR 2SC1623-L5L6		R538	1-216-691-11	METAL CHIP	47K 0.5% 1/10W
Q904	8-729-901-97	TRANSISTOR 2SA1036K-Q		R539	1-216-065-91	RES,CHIP	4.7K 5% 1/10W
<RESISTOR>				R540	1-216-691-11	METAL CHIP	47K 0.5% 1/10W
R401	1-249-383-11	CARBON	1.5 5% 1/4W F	R541	1-216-687-11	METAL CHIP	33K 0.5% 1/10W
R402	1-215-866-11	METAL OXIDE	330 5% 1W F	R542	1-214-842-11	METAL	120 1% 1/2W
R403	1-214-796-00	METAL	1.5 1% 1/2W	R543	1-214-842-11	METAL	120 1% 1/2W
R404	1-215-449-00	METAL	15K 1% 1/4W	R544	1-249-393-11	CARBON	10 5% 1/4W F
R405	1-214-796-00	METAL	1.5 1% 1/2W	R545	1-216-057-00	RES,CHIP	2.2K 5% 1/10W
R406	1-216-663-11	METAL CHIP	3.3K 0.5% 1/10W	R546	1-215-909-11	METAL OXIDE	47 5% 3W F
R407	1-249-397-11	CARBON	22 5% 1/4W F	R547	1-215-387-00	METAL	39 1% 1/4W
R409	1-216-679-11	METAL CHIP	15K 0.5% 1/10W	R548	1-260-318-71	CARBON	150 5% 1/2W
R410	1-216-663-11	METAL CHIP	3.3K 0.5% 1/10W	R549	1-260-314-11	CARBON	68 5% 1/2W
R416	1-216-073-00	RES,CHIP	10K 5% 1/10W	R550	1-247-903-00	CARBON	1M 5% 1/4W
				R552	1-249-437-11	CARBON	47K 5% 1/4W
				R553	1-249-437-11	CARBON	47K 5% 1/4W
				R555	1-249-437-11	CARBON	47K 5% 1/4W
				R557	1-249-437-11	CARBON	47K 5% 1/4W

The components identified  $\Delta$  marked are critical for safety.  
Replace only with the part number specified.

Les composants identifiés par la marque  $\Delta$  sont critiques pour la sécurité.  
Ne les remplacer que par une pièce portant le numéro spécifié.

CPD-E400/E400E/E400P



REF.NO.	PART NO.	DESCRIPTION	REMARK	REF.NO.	PART NO.	DESCRIPTION	REMARK
R559	1-249-437-11	CARBON 47K	5% 1/4W	R648	1-211-874-71	FUSIBLE MELF 0.12	10% 1/2W
R561	1-249-437-11	CARBON 47K	5% 1/4W	R649	1-211-874-71	FUSIBLE MELF 0.12	10% 1/2W
R563	1-249-405-11	CARBON 100	5% 1/4W F	R650	1-211-874-71	FUSIBLE MELF 0.12	10% 1/2W
R564	1-249-405-11	CARBON 100	5% 1/4W F	R651	1-249-441-11	CARBON 100K	5% 1/4W
R565	1-249-405-11	CARBON 100	5% 1/4W F	R652	1-215-923-00	METAL OXIDE 10K	5% 3W F
R566	1-249-405-11	CARBON 100	5% 1/4W F	R653	1-215-902-11	METAL OXIDE 47K	5% 2W F
R567	1-249-405-11	CARBON 100	5% 1/4W F	R656	1-215-467-00	METAL 82K	1% 1/4W
R568	1-249-405-11	CARBON 100	5% 1/4W F	R657	1-216-057-00	RES,CHIP 2.2K	5% 1/10W
R569	1-216-667-11	METAL CHIP 4.7K	0.5% 1/10W	R658	1-216-346-00	METAL OXIDE 0.56	5% 1W F
R570	1-216-674-11	METAL CHIP 9.1K	0.5% 1/10W	R659	1-249-425-11	CARBON 4.7K	5% 1/4W
R572	1-249-429-11	CARBON 10K	5% 1/4W	R660	1-215-465-00	METAL 68K	1% 1/4W
R573	1-216-385-11	METAL OXIDE 0.47	5% 3W F	R661	1-216-661-11	METAL CHIP 2.7K	0.5% 1/10W
R574	1-249-404-00	CARBON 82	5% 1/4W	R662	1-215-467-00	METAL 82K	1% 1/4W
R575	1-216-659-11	METAL CHIP 2.2K	0.5% 1/10W	R664	1-215-902-11	METAL OXIDE 47K	5% 2W F
R576	1-216-097-91	RES,CHIP 100K	5% 1/10W	R671	1-216-073-00	RES,CHIP 10K	5% 1/10W
R577	1-216-049-91	RES,CHIP 1K	5% 1/10W	R672	1-249-407-11	CARBON 150	5% 1/4W
R579	1-216-025-91	RES,CHIP 100	5% 1/10W	R673	1-216-073-00	RES,CHIP 10K	5% 1/10W
R580	1-216-659-11	METAL CHIP 2.2K	0.5% 1/10W	R674 $\Delta$	1-220-827-91	REGISTER 560K	5% 1/2W
R581	1-216-673-11	METAL CHIP 8.2K	0.5% 1/10W	R675	1-249-403-11	CARBON 68	5% 1/4W
R582	1-216-661-11	METAL CHIP 2.7K	0.5% 1/10W	R676	1-215-467-00	METAL 82K	1% 1/4W
R583	1-216-675-91	METAL CHIP 10K	0.5% 1/10W	R677	1-216-025-91	RES,CHIP 100	5% 1/10W
R584	1-216-473-11	METAL OXIDE 56	5% 3W F	R678	1-216-645-11	METAL CHIP 560	0.5% 1/10W
R585	1-216-381-11	METAL OXIDE 0.22	5% 3W F	R679	1-215-467-00	METAL 82K	1% 1/4W
R586	1-260-125-11	CARBON 150K	5% 1/2W	R680	1-216-661-11	METAL CHIP 2.7K	0.5% 1/10W
R587	1-216-641-11	METAL CHIP 390	0.5% 1/10W	R681	1-215-466-00	METAL 75K	1% 1/4W
R601	1-249-425-11	CARBON 4.7K	5% 1/4W	R682	1-215-463-00	METAL 56K	1% 1/4W
#2 R604	1-205-997-11	CEMENTED 2.2	5% 10W [E400/E400E]	R684	1-216-009-91	RES,CHIP 22	5% 1/10W
#2 R605	1-240-265-11	CMT-MELF 2.7	5% 10W [E400/E400E]	R685	1-216-073-00	RES,CHIP 10K	5% 1/10W
R615	1-216-615-91	METAL CHIP 33	0.5% 1/10W	R686	1-216-675-91	METAL CHIP 10K	0.5% 1/10W
R625	1-202-933-61	FUSIBLE 0.1	10% 1/2W	R687	1-216-689-11	RES,CHIP 39K	5% 1/10W
R626	1-215-927-00	METAL OXIDE 47K	5% 3W F	R689	1-216-663-11	METAL CHIP 3.3K	0.5% 1/10W
R627	1-219-513-11	CARBON 4.7M	5% 1/2W	R690	1-216-668-11	METAL CHIP 5.1K	0.5% 1/10W
#2 R628	1-216-115-00	RES,CHIP 560K	5% 1/10W [E400/E400E]	R691	1-216-661-11	METAL CHIP 2.7K	0.5% 1/10W
#2 R628	1-218-772-11	METAL CHIP 680K	0.5% 1/10W [E400P]	R692	1-216-081-00	RES,CHIP 22K	5% 1/10W
#2 R629	1-216-119-00	RES,CHIP 820K	5% 1/10W [E400/E400E]	R693	1-219-513-11	CARBON 4.7M	5% 1/2W
#2 R629	1-218-758-11	METAL CHIP 180K	0.5% 1/10W [E400P]	R697	1-215-927-00	METAL OXIDE 47K	5% 3W F
R630	1-216-635-11	METAL CHIP 220	0.5% 1/10W	R698	1-215-927-00	METAL OXIDE 47K	5% 3W F
R631	1-216-651-11	METAL CHIP 1K	0.5% 1/10W	R700	1-216-679-11	METAL CHIP 15K	0.5% 1/10W
R632	1-218-758-11	METAL CHIP 180K	0.5% 1/10W	R701	1-249-385-11	CARBON 2.2	5% 1/4W
R633	1-216-687-11	METAL CHIP 33K	0.5% 1/10W	R703	1-249-385-11	CARBON 2.2	5% 1/4W
R635	1-218-754-11	METAL CHIP 120K	0.5% 1/10W	R705	1-215-863-11	METAL OXIDE 100	5% 1W F
R636	1-249-397-11	CARBON 22	5% 1/4W F	R706	1-216-423-11	METAL OXIDE 27	5% 1W F
R637	1-215-893-11	METAL OXIDE 1.5K	5% 2W F	R707	1-216-679-11	METAL CHIP 15K	0.5% 1/10W
R638	1-215-893-11	METAL OXIDE 1.5K	5% 2W F	R708	1-216-353-00	METAL OXIDE 2.2	5% 1W F
R639	1-216-609-11	METAL CHIP 18	0.5% 1/10W	R709	1-216-667-11	METAL CHIP 4.7K	0.5% 1/10W
R640	1-216-344-00	METAL OXIDE 0.39	5% 1W F	R710	1-216-691-11	METAL CHIP 47K	0.5% 1/10W
R641	1-216-345-11	METAL OXIDE 0.47	5% 1W F	R711	1-216-675-91	METAL CHIP 10K	0.5% 1/10W
R642	1-249-381-11	CARBON 1	5% 1/4W F	R712	1-216-679-11	METAL CHIP 15K	0.5% 1/10W
R643	1-247-791-91	CARBON 22	5% 1/4W	R713	1-215-858-00	METAL OXIDE 15	5% 1W F
R644	1-247-807-31	CARBON 100	5% 1/4W	R714	1-215-863-11	METAL OXIDE 100	5% 1W F
R645	1-211-874-71	FUSIBLE MELF 0.12	10% 1/2W	R715	1-216-353-00	METAL OXIDE 2.2	5% 1W F
				R716	1-249-377-11	CARBON 0.47	5% 1/4W F
				R717	1-249-377-11	CARBON 0.47	5% 1/4W F
				R718	1-216-426-11	METAL OXIDE 82	5% 1W F
				R719	1-216-369-00	METAL OXIDE 1	5% 2W F
				R720	1-216-295-91	SHORT 0	

# CPD-E400/E400E/E400P



The components identified by **D** in this manual have been carefully factory-selected for each set in order to satisfy regulations regarding X-ray radiation. Should replacement be required, replace only with the value originally used.

Les composants identifiés par la marque **△** sont critiques pour la sécurité.  
Ne les remplacer que par une pièce portant le numéro spécifié.

The components identified **△** marked are critical for safety.  
Replace only with the part number specified.

REF.NO.	PART NO.	DESCRIPTION	REMARK	REF.NO.	PART NO.	DESCRIPTION	REMARK
R721	1-216-659-11	METAL CHIP 2.2K	0.5% 1/10W	R926	1-216-073-00	RES,CHIP 10K	5% 1/10W
R722	1-216-426-11	METAL OXIDE 82	5% 1W F	R927	1-220-823-91	CARBON 6.8K	5% 1/2W
R723	1-216-295-91	SHORT 0		R928	1-220-825-11	CARBON 330K	5% 1/2W
R724	1-216-659-11	METAL CHIP 2.2K	0.5% 1/10W	R929	1-216-089-91	RES,CHIP 47K	5% 1/10W
R725	1-216-369-00	METAL OXIDE 1	5% 2W F	R930	1-219-748-11	CARBON 4.7K	5% 1/2W
R726	1-216-667-11	METAL CHIP 4.7K	0.5% 1/10W	R931	1-219-748-11	CARBON 4.7K	5% 1/2W
R727	1-216-666-11	METAL CHIP 4.3K	0.5% 1/10W	R932	1-216-673-11	METAL CHIP 8.2K	0.5% 1/10W
R728	1-216-659-11	METAL CHIP 2.2K	0.5% 1/10W	R933	1-216-666-11	METAL CHIP 4.3K	0.5% 1/10W
R729	1-216-667-11	METAL CHIP 4.7K	0.5% 1/10W	R934	1-249-377-11	CARBON 0.47	5% 1/4W F
R730	1-216-073-00	RES,CHIP 10K	5% 1/10W	R1001	1-216-675-91	METAL CHIP 10K	0.5% 1/10W
R731	1-216-081-00	RES,CHIP 22K	5% 1/10W	R1003	1-216-025-91	RES,CHIP 100	5% 1/10W
R732	1-249-383-11	CARBON 1.5	5% 1/4W F	R1004	1-216-033-00	RES,CHIP 220	5% 1/10W
R733	1-215-859-00	METAL OXIDE 22	5% 1W F	R1005	1-247-815-91	CARBON 220	5% 1/4W
R734	1-215-864-00	METAL OXIDE 150	5% 1W F	R1006	1-216-033-00	RES,CHIP 220	5% 1/10W
R735	1-216-057-00	RES,CHIP 2.2K	5% 1/10W	R1010	1-216-033-00	RES,CHIP 220	5% 1/10W
R736	1-216-049-91	RES,CHIP 1K	5% 1/10W	R1011	1-216-049-91	RES,CHIP 1K	5% 1/10W
R737	1-216-049-91	RES,CHIP 1K	5% 1/10W	R1012	1-216-017-91	RES,CHIP 47	5% 1/10W
R738	1-216-071-00	RES,CHIP 8.2K	5% 1/10W	R1013	1-216-017-91	RES,CHIP 47	5% 1/10W
R739	1-249-434-11	CARBON 27K	5% 1/4W	R1014	1-216-025-91	RES,CHIP 100	5% 1/10W
R740	1-216-089-91	RES,CHIP 47K	5% 1/10W	R1015	1-216-033-00	RES,CHIP 220	5% 1/10W
R741	1-216-049-91	RES,CHIP 1K	5% 1/10W	R1016	1-216-033-00	RES,CHIP 220	5% 1/10W
R742	1-216-067-00	RES,CHIP 5.6K	5% 1/10W	R1017	1-216-057-00	RES,CHIP 2.2K	5% 1/10W
R743	1-216-037-00	RES,CHIP 330	5% 1/10W	R1018	1-216-057-00	RES,CHIP 2.2K	5% 1/10W
R744	1-249-413-11	CARBON 470	5% 1/4W F	R1019	1-216-017-91	RES,CHIP 47	5% 1/10W
R745	1-249-389-11	CARBON 4.7	5% 1/4W F	R1020	1-216-017-91	RES,CHIP 47	5% 1/10W
R746	1-249-389-11	CARBON 4.7	5% 1/4W F	R1021	1-216-025-91	RES,CHIP 100	5% 1/10W
R747	1-216-357-00	METAL OXIDE 4.7	5% 1W F	R1022	1-216-025-91	RES,CHIP 100	5% 1/10W
R748	1-219-752-11	CARBON 100K	5% 1/2W	R1039	1-216-065-91	RES,CHIP 4.7K	5% 1/10W
R749	1-215-437-00	METAL 4.7K	1% 1/4W	R1046	1-216-065-91	RES,CHIP 4.7K	5% 1/10W
R751	1-216-073-00	RES,CHIP 10K	5% 1/10W	R1047	1-216-065-91	RES,CHIP 4.7K	5% 1/10W
R752	1-216-085-00	RES,CHIP 33K	5% 1/10W	R1048	1-216-065-91	RES,CHIP 4.7K	5% 1/10W
R753	1-249-393-11	CARBON 10	5% 1/4W F	R1049	1-216-065-91	RES,CHIP 4.7K	5% 1/10W
R754	1-216-677-11	METAL CHIP 12K	0.5% 1/10W	R1050	1-216-065-91	RES,CHIP 4.7K	5% 1/10W
R755	1-216-675-91	METAL CHIP 10K	0.5% 1/10W	R1051	1-216-065-91	RES,CHIP 4.7K	5% 1/10W
R901	1-216-097-91	RES,CHIP 100K	5% 1/10W	R1065	1-216-065-91	RES,CHIP 4.7K	5% 1/10W
R902	1-216-089-91	RES,CHIP 47K	5% 1/10W	R1070	1-216-065-91	RES,CHIP 4.7K	5% 1/10W
R904	1-216-057-00	RES,CHIP 2.2K	5% 1/10W	R1072	1-216-065-91	RES,CHIP 4.7K	5% 1/10W
R905	1-216-049-91	RES,CHIP 1K	5% 1/10W	R1073	1-216-049-91	RES,CHIP 1K	5% 1/10W
R906	1-216-699-91	METAL CHIP 100K	0.5% 1/10W	R1074	1-216-049-91	RES,CHIP 1K	5% 1/10W
R907	1-216-295-91	SHORT 0		R1083	1-216-025-91	RES,CHIP 100	5% 1/10W
R908	1-249-425-11	CARBON 4.7K	5% 1/4W	R1084	1-216-041-00	RES,CHIP 470	5% 1/10W
R909	1-215-913-11	METAL OXIDE 220	5% 3W F	R1085	1-216-025-91	RES,CHIP 100	5% 1/10W
R910	1-215-913-11	METAL OXIDE 220	5% 3W F	R1086	1-216-073-00	RES,CHIP 10K	5% 1/10W
R911	1-249-397-11	CARBON 22	5% 1/4W F	R1092	1-216-033-00	RES,CHIP 220	5% 1/10W
R912	1-216-049-91	RES,CHIP 1K	5% 1/10W	R1093	1-216-033-00	RES,CHIP 220	5% 1/10W
R914	1-216-041-00	RES,CHIP 470	5% 1/10W	R1094	1-216-113-00	RES,CHIP 470K	5% 1/10W
R915	1-249-397-11	CARBON 22	5% 1/4W F	R1095	1-216-073-00	RES,CHIP 10K	5% 1/10W
R916	1-249-385-11	CARBON 2.2	5% 1/4W F	R1096	1-216-073-00	RES,CHIP 10K	5% 1/10W
R917	1-249-385-11	CARBON 2.2	5% 1/4W F	R1097	1-216-077-91	RES,CHIP 15K	5% 1/10W
R918	1-214-964-00	METAL 1M	1% 1/4W	R1098	1-216-077-91	RES,CHIP 15K	5% 1/10W
R919	1-216-073-00	RES,CHIP 10K	5% 1/10W	R1099	1-216-033-00	RES,CHIP 220	5% 1/10W
R920	1-216-691-11	METAL CHIP 47K	0.5% 1/10W	R1104	1-216-065-91	RES,CHIP 4.7K	5% 1/10W
R921	1-216-049-91	RES,CHIP 1K	5% 1/10W				
R923	1-215-469-00	METAL 100K	1% 1/4W				
R924	1-216-675-91	METAL CHIP 10K	0.5% 1/10W				
R925	1-218-762-11	METAL CHIP 270K	0.5% 1/10W				
						<VARIABLE RESISTOR>	
				△RV901	1-241-767-21	RES, ADJ, CERMET	100K





# CPD-E400/E400E/E400P



REF.NO.	PART NO.	DESCRIPTION	REMARK	REF.NO.	PART NO.	DESCRIPTION	REMARK
C817	1-119-941-91	ELECT	470μF 20% 6.3V	<RESISTOR>			
C818	1-113-340-11	ELECT	47μF 20% 25V	R801	1-216-677-11	METAL CHIP 12K	0.5% 1/10W
C819	1-163-037-11	CERAMIC CHIP	0.022μF 10% 50V	R802	1-216-677-11	METAL CHIP 12K	0.5% 1/10W
C820	1-119-941-91	ELECT	470μF 20% 6.3V	R803	1-216-033-00	RES,CHIP 220	5% 1/10W
C821	1-163-038-91	CERAMIC CHIP	0.1μF 25V	R804	1-216-033-00	RES,CHIP 220	5% 1/10W
C822	1-164-004-11	CERAMIC CHIP	0.1μF 10% 25V	R805	1-216-033-00	RES,CHIP 220	5% 1/10W
C823	1-163-038-91	CERAMIC CHIP	0.1μF 25V	R806	1-216-033-00	RES,CHIP 220	5% 1/10W
C824	1-163-133-00	CERAMIC CHIP	470pF 5% 50V	R807	1-216-033-00	RES,CHIP 220	5% 1/10W
C825	1-163-021-91	CERAMIC CHIP	0.01μF 10% 50V	R808	1-216-033-00	RES,CHIP 220	5% 1/10W
C826	1-164-004-11	CERAMIC CHIP	0.1μF 10% 25V	R809	1-216-651-11	METAL CHIP 1K	0.5% 1/10W
C827	1-119-941-91	ELECT	470μF 20% 6.3V	R810	1-216-651-11	METAL CHIP 1K	0.5% 1/10W
C828	1-164-161-11	CERAMIC CHIP	0.0022μF 10% 50V	R811	1-216-053-00	RES,CHIP 1.5K	5% 1/10W
C829	1-164-004-11	CERAMIC CHIP	0.1μF 10% 25V	R812	1-216-049-91	RES,CHIP 1K	5% 1/10W
C830	1-113-340-11	ELECT	47μF 20% 25V	R813	1-216-049-91	RES,CHIP 1K	5% 1/10W
C832	1-131-722-91	ELECT	100μF 20% 6.3V	R814	1-216-031-00	RES,CHIP 180	5% 1/10W
C833	1-163-038-91	CERAMIC CHIP	0.1μF 25V	R815	1-216-073-00	RES,CHIP 10K	5% 1/10W
C835	1-163-038-91	CERAMIC CHIP	0.1μF 25V	R816	1-218-768-11	METAL CHIP 470K	0.5% 1/10W
C837	1-163-017-00	CERAMIC CHIP	0.0047μF 10% 50V	R818	1-216-049-91	RES,CHIP 1K	5% 1/10W
C838	1-163-017-00	CERAMIC CHIP	0.0047μF 10% 50V	R819	1-216-049-91	RES,CHIP 1K	5% 1/10W
C839	1-163-017-00	CERAMIC CHIP	0.0047μF 10% 50V	R820	1-216-049-91	RES,CHIP 1K	5% 1/10W
C840	1-163-017-00	CERAMIC CHIP	0.0047μF 10% 50V	R821	1-216-049-91	RES,CHIP 1K	5% 1/10W
C841	1-163-023-00	CERAMIC CHIP	0.015μF 10% 50V	R822	1-216-049-91	RES,CHIP 1K	5% 1/10W
<CONNECTOR>				R823	1-216-667-11	METAL CHIP 4.7K	0.5% 1/10W
CN801	1-793-585-11	PIN, CONNECTOR (PC BOARD)	15P	R824	1-216-073-00	RES,CHIP 10K	5% 1/10W
CN802	1-793-586-11	PIN, CONNECTOR (PC BOARD)	15P	R825	1-216-671-11	METAL CHIP 6.8K	0.5% 1/10W
<DIODE>				R826	1-216-671-11	METAL CHIP 6.8K	0.5% 1/10W
D802	8-719-049-09	DIODE ISS367-T3 SONY		R827	1-216-073-00	RES,CHIP 10K	5% 1/10W
<FERRITE BEAD>				R828	1-216-667-11	METAL CHIP 4.7K	0.5% 1/10W
FB801	1-543-960-22	FERRITE		R829	1-216-049-91	RES,CHIP 1K	5% 1/10W
FB802	1-216-295-91	SHORT	0	R830	1-216-049-91	RES,CHIP 1K	5% 1/10W
FB809	1-543-963-22	FERRITE		R831	1-216-033-00	RES,CHIP 220	5% 1/10W
FB810	1-543-963-22	FERRITE		R832	1-216-025-91	RES,CHIP 100	5% 1/10W
<IC>				R833	1-216-651-11	METAL CHIP 1K	0.5% 1/10W
IC801	8-759-589-56	IC CXD9517Q		R834	1-216-647-11	METAL CHIP 680	0.5% 1/10W
IC802	8-759-569-45	IC LD1117S33TR		R835	1-216-089-91	RES,CHIP 47K	5% 1/10W
IC803	8-759-502-82	IC LM324M		R836	1-216-049-91	RES,CHIP 1K	5% 1/10W
<CHIP CONDUCTOR>				R837	1-216-648-11	METAL CHIP 750	0.5% 1/10W
JR801	1-216-295-91	SHORT	0	R838	1-216-041-00	RES,CHIP 470	5% 1/10W
JR802	1-216-295-91	SHORT	0	R839	1-216-117-00	RES,CHIP 680K	5% 1/10W
<TRANSISTOR>				R840	1-216-650-11	METAL CHIP 910	0.5% 1/10W
Q801	8-729-120-28	TRANSISTOR 2SC1623-L5L6		R841	1-216-089-91	RES,CHIP 47K	5% 1/10W
Q804	8-729-026-50	TRANSISTOR 2SA1037AK-T146-QR		R842	1-216-677-11	METAL CHIP 12K	0.5% 1/10W
Q805	8-729-026-50	TRANSISTOR 2SA1037AK-T146-QR		R843	1-216-069-00	RES,CHIP 6.8K	5% 1/10W
				R844	1-216-017-91	RES,CHIP 47	5% 1/10W
				R846	1-216-025-91	RES,CHIP 100	5% 1/10W
				R847	1-216-667-11	METAL CHIP 4.7K	0.5% 1/10W
				R851	1-216-065-91	RES,CHIP 4.7K	5% 1/10W
				R852	1-216-065-91	RES,CHIP 4.7K	5% 1/10W
				R853	1-216-049-00	RES,CHIP 1K	5% 1/10W
				R855	1-216-105-91	RES,CHIP 220K	5% 1/10W
				R856	1-216-073-00	RES,CHIP 10K	5% 1/10W
				R857	1-216-049-91	RES,CHIP 1K	5% 1/10W
				R858	1-216-073-00	RES,CHIP 10K	5% 1/10W
				R859	1-216-025-91	RES,CHIP 100	5% 1/10W
				R860	1-216-025-91	RES,CHIP 100	5% 1/10W
				R863	1-216-065-91	RES,CHIP 4.7K	5% 1/10W

<u>REF.NO.</u>	<u>PART NO.</u>	<u>DESCRIPTION</u>	<u>REMARK</u>		
R864	1-216-025-91	RES,CHIP	100	5%	1/10W
R866	1-216-049-91	RES,CHIP	1K	5%	1/10W

\*\*\*\*\*

